



DANGER

Danger of electrical shock, burns or death. Always remove all power sources before attempting any repair, service or diagnostic work. Power can be present from shore power, generator, inverter or battery. All power sources must be disabled and secured before performing any service.



CAUTION

If you lack the skills, tools or equipment to perform diagnostic or repair work leave such work to an authorized Winnebago Industries dealer or other qualified shop.

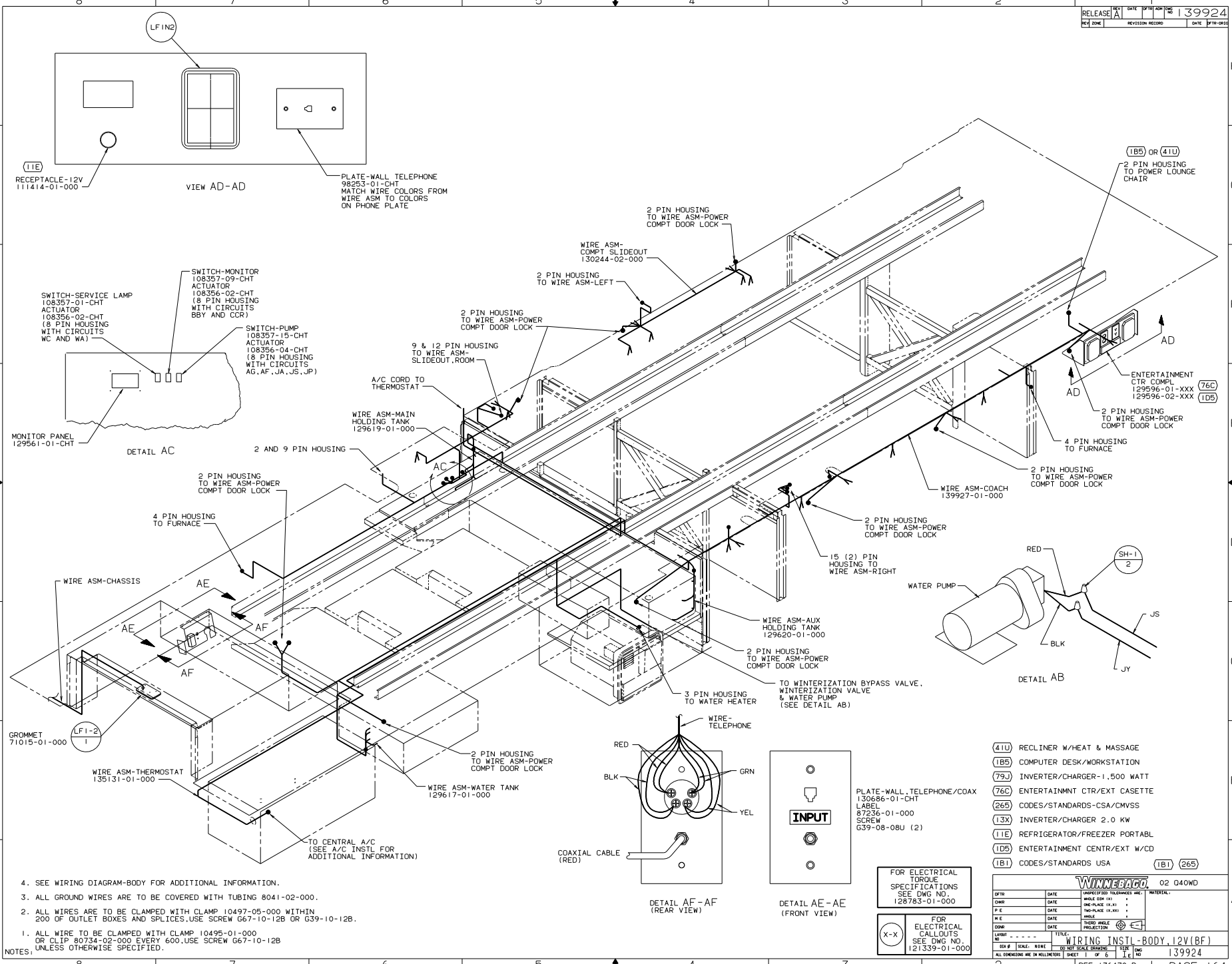

(11E) RECEPTACLE-12V
 111414-01-000

VIEW AD-AD

PLATE-WALL TELEPHONE
 98253-01-CHT
 MATCH WIRE COLORS FROM
 WIRE ASM TO COLORS
 ON PHONE PLATE

SWITCH-MONITOR
 108357-09-CHT
 ACTUATOR

SWITCH-SERVICE LAMP
 108357-01-CHT
 ACTUATOR

SWITCH-PUMP
 108357-15-CHT
 ACTUATOR

SWITCH-8 PIN HOUSING
 WITH CIRCUITS
 BBY AND CCR)

SWITCH-8 PIN HOUSING
 WITH CIRCUITS
 AG, AF, JA, JS, JP)

MONITOR PANEL
 129561-01-CHT

DETAIL AC

2 PIN HOUSING
 TO WIRE ASM-POWER
 COMPT DOOR LOCK

4 PIN HOUSING
 TO FURNACE

WIRE ASM-CHASSIS

AE

AF

GROMMET
 71015-01-000

LF1-2

WIRE ASM-THERMOSTAT
 135131-01-000

TO CENTRAL A/C
 (SEE A/C INSTL FOR
 ADDITIONAL INFORMATION)

2 AND 9 PIN HOUSING

WIRE ASM-MAIN
 HOLDING TANK
 129619-01-000

A/C CORD TO
 THERMOSTAT

9 & 12 PIN HOUSING
 TO WIRE ASM-
 SLIDEOUT, ROOM

2 PIN HOUSING
 TO WIRE ASM-POWER
 COMPT DOOR LOCK

2 PIN HOUSING
 TO WIRE ASM-LEFT

WIRE ASM-COACH
 139927-01-000

2 PIN HOUSING
 TO WIRE ASM-POWER
 COMPT DOOR LOCK

15 (2) PIN
 HOUSING TO
 WIRE ASM-RIGHT

WIRE ASM-AUX
 HOLDING TANK
 129620-01-000

2 PIN HOUSING
 TO WIRE ASM-POWER
 COMPT DOOR LOCK

3 PIN HOUSING
 TO WATER HEATER

TO WINTERIZATION BYPASS VALVE,
 WINTERIZATION VALVE
 & WATER PUMP
 (SEE DETAIL AB)

WIRE-
 TELEPHONE

RED

BLK

GRN

YEL

COAXIAL CABLE
 (RED)

2 PIN HOUSING
 TO WIRE ASM-POWER
 COMPT DOOR LOCK

WIRE ASM-WATER TANK
 129617-01-000

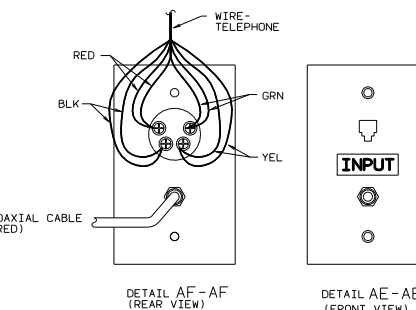

(1B5) OR (41U)
 2 PIN HOUSING
 TO POWER LOUNGE
 CHAIR

ENTERTAINMENT
 CTR COMPL
 129596-01-XXX (76C)
 129596-02-XXX (1D5)

2 PIN HOUSING
 TO WIRE ASM-POWER
 COMPT DOOR LOCK

4 PIN HOUSING
 TO FURNACE

2 PIN HOUSING
 TO WIRE ASM-POWER
 COMPT DOOR LOCK

WATER PUMP

RED

SH-1
 2

BLK

JS

JY

DETAIL AB

- (41U) RECLINER W/HEAT & MASSAGE
- (1B5) COMPUTER DESK/WORKSTATION
- (79J) INVERTER/CHARGER-1,500 WATT
- (76C) ENTERTAINMENT CTR/EXT CASSETTE
- (265) CODES/STANDARDS-CSA/CMVSS
- (13X) INVERTER/CHARGER 2.0 KW
- (11E) REFRIGERATOR/FREEZER PORTABLE
- (1D5) ENTERTAINMENT CENTR/EXT W/CD
- (1B1) CODES/STANDARDS USA

| | | | | |
|------|------|-------------------------------|-----|----------|
| DATE | | UNSPECIFIED TORQUE | AMT | MATERIAL |
| DATE | DATE | MADE TO ORDER | | |
| DATE | DATE | ONE-PLACE (1,000) | | |
| DATE | DATE | TWO-PLACE (10,000) | | |
| DATE | DATE | THREE-PLACE (100,000) | | |
| DATE | DATE | FOUR-PLACE (1,000,000) | | |
| DATE | DATE | FIVE-PLACE (10,000,000) | | |
| DATE | DATE | SIX-PLACE (100,000,000) | | |
| DATE | DATE | SEVEN-PLACE (1,000,000,000) | | |
| DATE | DATE | EIGHT-PLACE (10,000,000,000) | | |
| DATE | DATE | NINE-PLACE (100,000,000,000) | | |
| DATE | DATE | TEN-PLACE (1,000,000,000,000) | | |

02 040WD

WIRING INSTL-BODY, 12V(BF)

139924

REF: 136470 P PAGE 164

4. SEE WIRING DIAGRAM-BODY FOR ADDITIONAL INFORMATION.
3. ALL GROUND WIRES ARE TO BE COVERED WITH TUBING 8041-02-000.
2. ALL WIRES ARE TO BE CLAMPED WITH CLAMP 10497-05-000 WITHIN 200 OF OUTLET BOXES AND SPLICES USE SCREW G67-10-12B OR G39-10-12B.
1. ALL WIRE TO BE CLAMPED WITH CLAMP 10495-01-000 OR CLIP 80734-02-000 EVERY 600. USE SCREW G67-10-12B UNLESS OTHERWISE SPECIFIED.

NOTES:

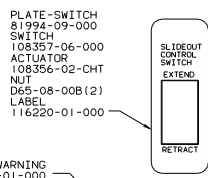
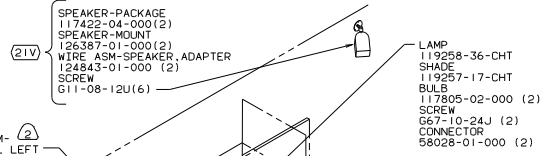
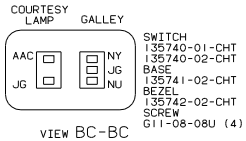
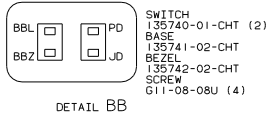

WARNING! UNDERSTAND OPERATOR'S MANUAL BEFORE USING. KEEP PEOPLE AND OBSTRUCTIONS CLEAR OF SLIDEOUT ROOM WHEN OPERATING TO AVOID INJURY AND/OR PROPERTY DAMAGE.

LABEL-WARNING
116549-01-000

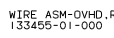
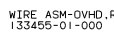
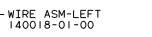
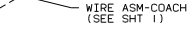
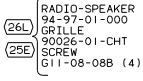
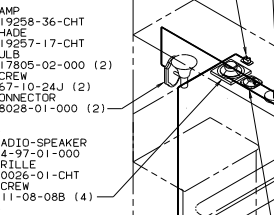
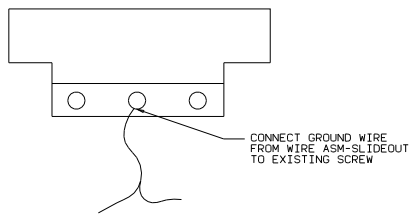
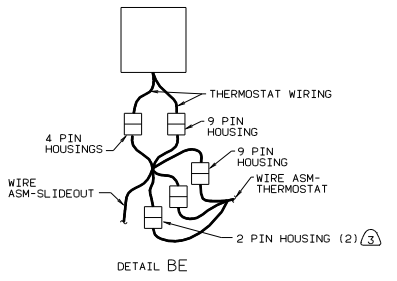
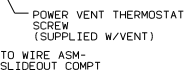
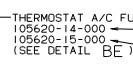
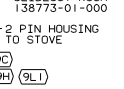
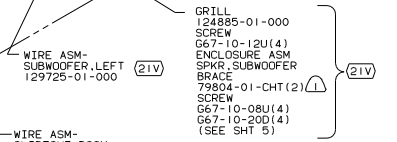
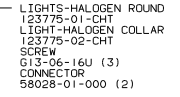
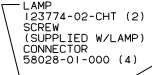
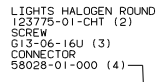
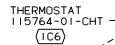
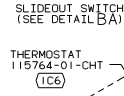
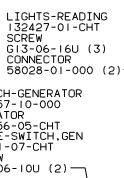

TO RIGHT SIDE

TO EXTERIOR SERVICE LAMP

(3) WITHOUT (29H) PLUG THE TWO, TWO PIN HOUSINGS TOGETHER ON WIRE ASM-SLIDEOUT.

(2) WIRE ROUTED IN SIDEWALL.

(1) ATTACH BRACE TO SIDE OF SUBWOOFER AND SCREW DOWN TO FLOOR.

FOR ELECTRICAL TORQUE SPECIFICATIONS SEE DWG NO. 128783-01-000

FOR ELECTRICAL CALLOUTS SEE DWG NO. 121339-01-000

- (9L1) HOME COMFORT PLUS PACKAGE
- (29H) HEAT PUMP-A/C CENTRAL
- (29C) A/C CENTRAL
- (670) GEN-7.5KW-ONAN-QUIET DIESEL
- (321) GENERATOR PREP KIT
- (265) CODES/STANDARDS-CSA/CMVSS
- (26L) REAR STEREO SYSTEM W/CASSETTE
- (28E) REAR STEREO SYSTEM W/CD
- (21V) SOUND SYSTEM DELUXE
- (1C6) FURNACE-25.000 BTU
- (1B1) CODES/STANDARDS USA

| | | |
|---------------------------------|-------|------------|
| 02 | Q40WD | (1B1)(265) |
| TITLE: WIRING INSTL-BODY 12V(L) | | |
| NO. 1 | DATE | 139924 |
| 2 | REV | |
| 3 | REV | |
| 4 | REV | |
| 5 | REV | |
| 6 | REV | |

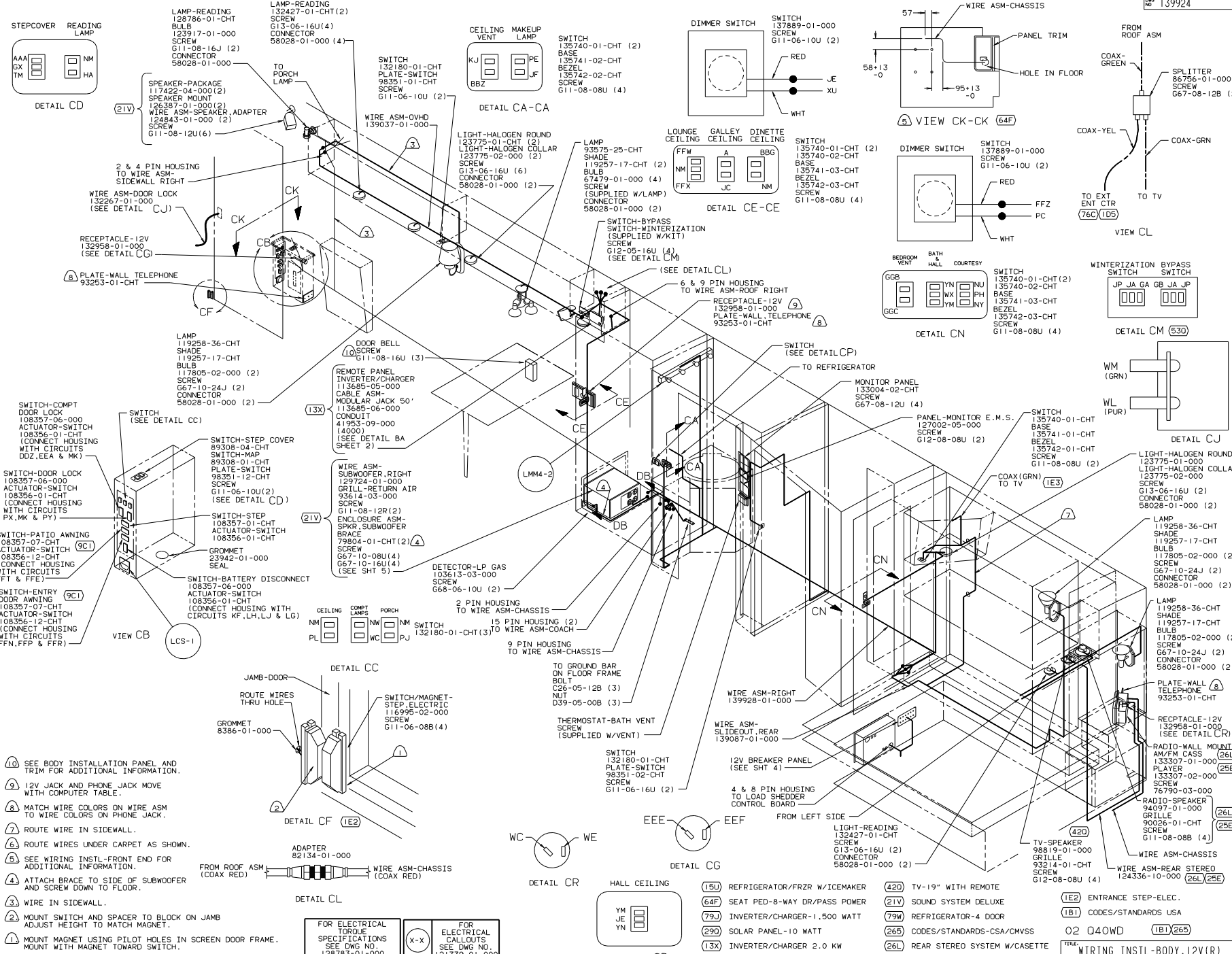

- NOTES:
- (1) MOUNT SWITCH AND SPACER TO BLOCK ON JAMB ADJUST HEIGHT TO MATCH MAGNET.
 - (2) MOUNT MAGNET USING PILOT HOLES IN SCREEN DOOR FRAME. MOUNT WITH MAGNET TOWARD SWITCH.
 - (3) WIRE IN SIDEWALL.
 - (4) ATTACH BRACE TO SIDE OF SUBWOOFER AND SCREW DOWN TO FLOOR.
 - (5) SEE WIRING INSTL-FRONT END FOR ADDITIONAL INFORMATION.
 - (6) ROUTE WIRES UNDER CARPET AS SHOWN.
 - (7) ROUTE WIRE IN SIDEWALL.
 - (8) MATCH WIRE COLORS ON WIRE ASM TO WIRE COLORS ON PHONE JACK.
 - (9) 12V JACK AND PHONE JACK MOVE WITH COMPUTER TABLE.
 - (10) SEE BODY INSTALLATION PANEL AND TRIM FOR ADDITIONAL INFORMATION.

FOR ELECTRICAL TORQUE SPECIFICATIONS SEE DWG NO. 128783-01-000

(X-X)

FOR ELECTRICAL CALLOUTS SEE DWG NO. 121339-01-000

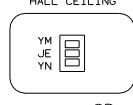

- (15) REFRIGERATOR/FRZR W/ICEMAKER
- (64F) SEAT PED-8-WAY DR/PASS POWER
- (79J) INVERTER/CHARGER-1,500 WATT
- (290) SOLAR PANEL-10 WATT
- (13X) INVERTER/CHARGER 2.0 KW
- (IE3) ENERGY MANAGEMENT SYSTEM

- (420) TV-19" WITH REMOTE
- (21V) SOUND SYSTEM DELUXE
- (79N) REFRIGERATOR-4 DOOR
- (265) CODES/STANDARDS-CSA/CMVSS
- (26L) REAR STEREO SYSTEM W/CASSETTE
- (25E) REAR STEREO SYSTEM W/CD

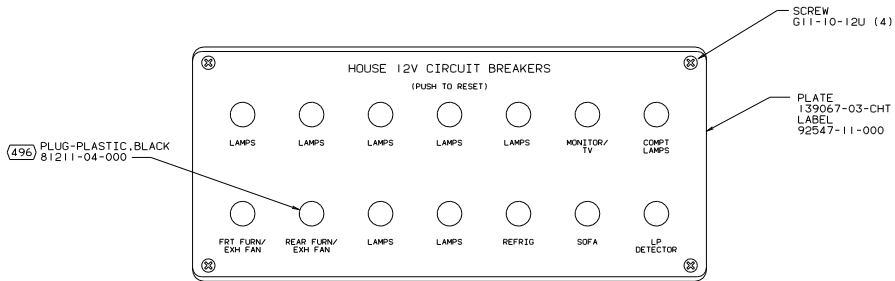

CIRCUIT BREAKER (FRONT VIEW)

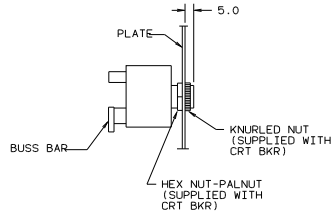

SECTION DC-DC

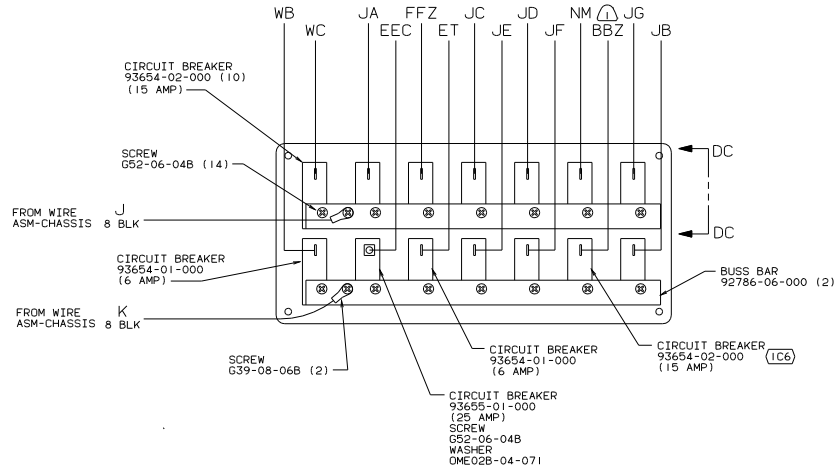

CIRCUIT BREAKER (BACK VIEW)

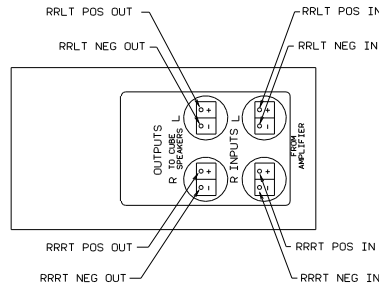

VIEW DB (SHT 3)

REAR BOSE WOOFER

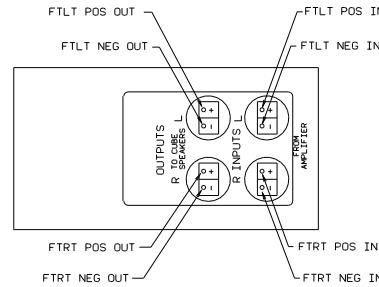

VIEW DA (SHT 2)

FRONT BOSE WOOFER

- (496) FURNACE WITHOUT
- (1C6) FURNACE-25,000 BTU
- (265) CODES/STANDARDS-CSA/CMVSS
- (1B1) CODES/STANDARDS USA

FOR ELECTRICAL TORQUE SPECIFICATIONS SEE DWG NO. 128783-01-000

| | |
|----------------------|----------------------------|
| 02 Q40WD (1B1) (265) | |
| TITLE | WIRING INSTL-BODY, 12V(BP) |
| NO. OF SCALE DRAWING | SHEET NO. 4 OF 6 |
| DATE | 139924 |

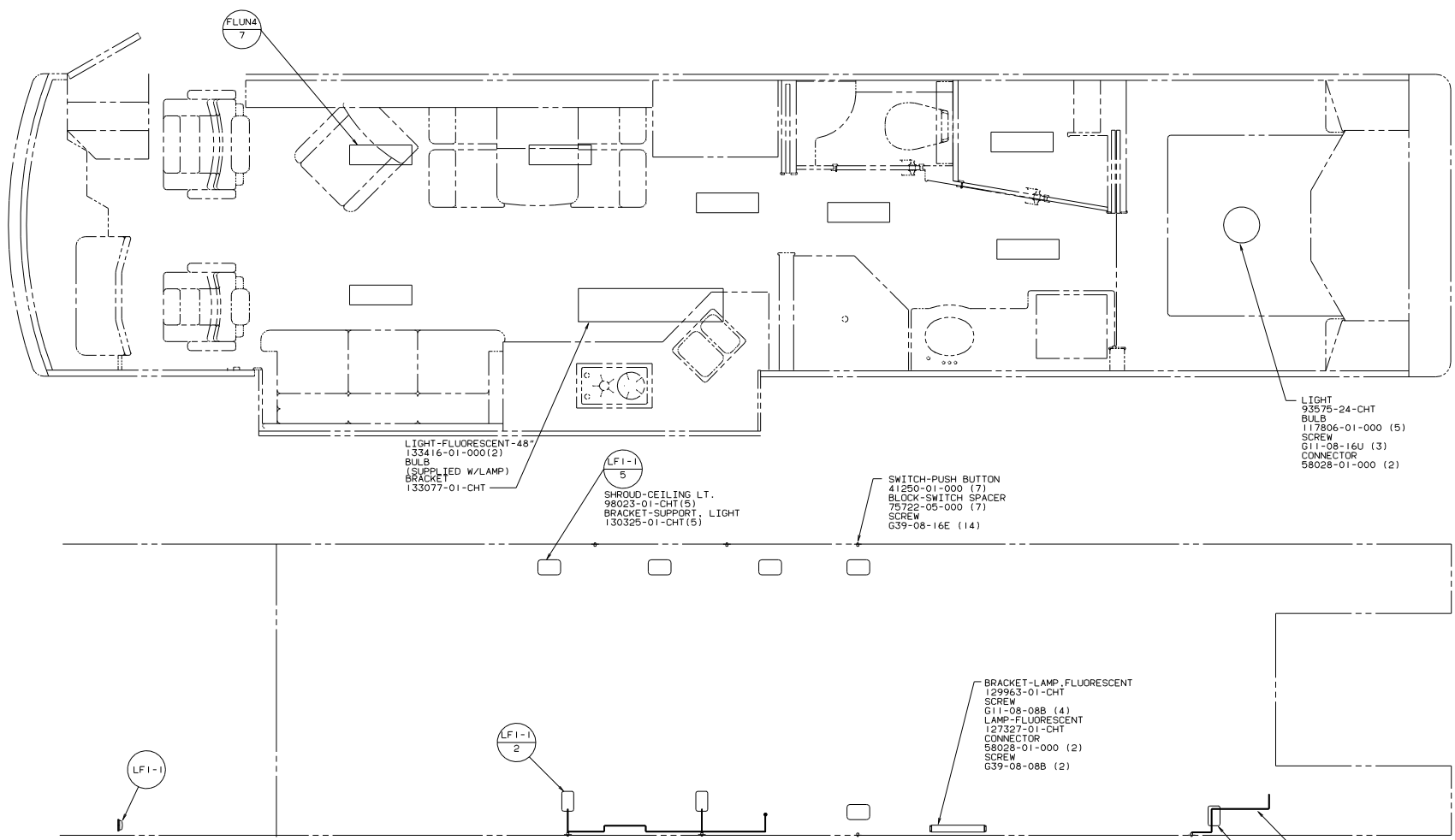

FLUN4
7

LIGHT-FLUORESCENT-48"
133416-01-000(2)
BULB
(SUPPLIED W/LAMP)
BRACKET
133077-01-CHT

LF1-1
5

SHROUD-CEILING LT.
98023-01-CHT(5)
BRACKET-SUPPORT, LIGHT
130325-01-CHT(5)

SWITCH-PUSH BUTTON
41250-01-000 (7)
BLOCK-SWITCH SPACER
75722-05-000 (7)
SCREW
G39-08-16E (14)

LIGHT
93575-24-CHT
BULB
117806-01-000 (5)
SCREW
G11-08-16U (3)
CONNECTOR
58028-01-000 (2)

LF1-1

LF1-1
2

BRACKET-LAMP, FLUORESCENT
129963-01-CHT
SCREW
G11-08-08B (4)
LAMP-FLUORESCENT
127327-01-CHT
CONNECTOR
58028-01-000 (2)
SCREW
G39-08-08B (2)

LFN13

WIRE ASM-CHASSIS

NOTES:

(265) CODES/STANDARDS-CSA/CMVSS
(1B1) CODES/STANDARDS USA

FOR ELECTRICAL
TORQUE
SPECIFICATIONS
SEE DWG NO.
128783-01-000

(X-X)
FOR
ELECTRICAL
CALLOUTS
SEE DWG NO.
121339-01-000

02 040WD (1B1)265
TITLE: WIRING INSTL-BODY,12V(CL)
DWG NO. 139924
SHEET 5 OF 6 I.F. NO.

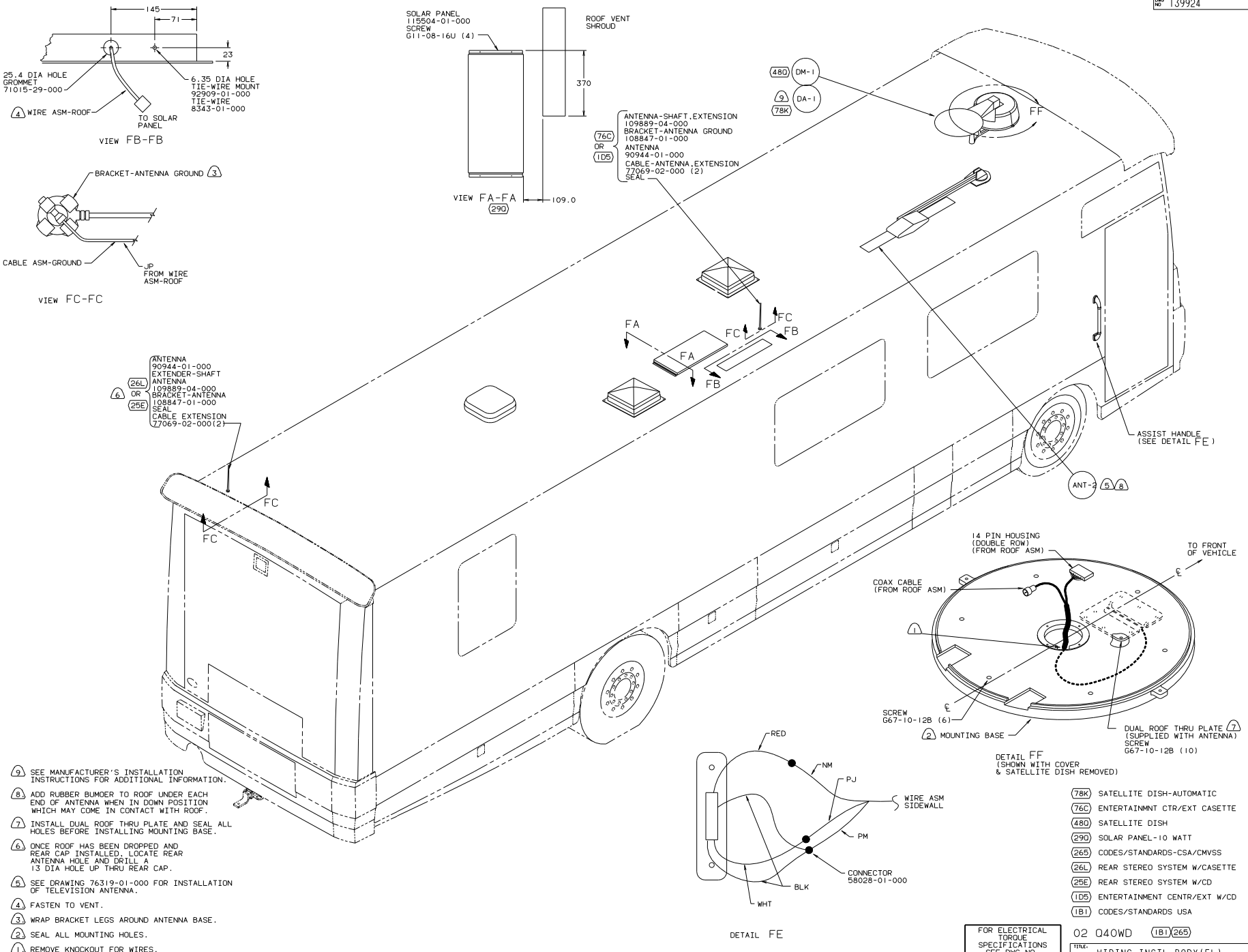

- (26L) ANTENNA 90944-01-000
- (26L) EXTENDER-SHAFT ANTENNA 109889-04-000
- OR
- (26E) BRACKET-ANTENNA 108847-01-000
- (26E) SEAL CABLE EXTENSION 77069-02-000 (2)

- (9) SEE MANUFACTURER'S INSTALLATION INSTRUCTIONS FOR ADDITIONAL INFORMATION.
- (8) ADD RUBBER BUMPER TO ROOF UNDER EACH END OF ANTENNA WHEN IN DOWN POSITION WHICH MAY COME IN CONTACT WITH ROOF.
- (7) INSTALL DUAL ROOF THRU PLATE AND SEAL ALL HOLES BEFORE INSTALLING MOUNTING BASE.
- (6) ONCE ROOF HAS BEEN DROPPED AND REAR CAP INSTALLED, LOCATE REAR ANTENNA HOLE AND DRILL A 13 DIA HOLE UP THRU REAR CAP.
- (5) SEE DRAWING 76319-01-000 FOR INSTALLATION OF TELEVISION ANTENNA.
- (4) FASTEN TO VENT.
- (3) WRAP BRACKET LEGS AROUND ANTENNA BASE.
- (2) SEAL ALL MOUNTING HOLES.
- (1) REMOVE KNOCKOUT FOR WIRES.

NOTES:

FOR ELECTRICAL TORQUE SPECIFICATIONS SEE DWG NO 128783-01-000

- (78K) SATELLITE DISH-AUTOMATIC
- (76C) ENTERTAINMENT CTR/EXT CASSETTE
- (480) SATELLITE DISH
- (290) SOLAR PANEL-10 WATT
- (265) CODES/STANDARDS-CSA/CMVSS
- (26L) REAR STEREO SYSTEM W/CASSETTE
- (26E) REAR STEREO SYSTEM W/CD
- (1D5) ENTERTAINMENT CENTR/EXT W/CD
- (1B1) CODES/STANDARDS USA

02 Q40WD (1B1)(265)
 TITLE: WIRING INSTL-BODY(EL)
 DO NOT SCALE DRAWING
 SHEET 6 OF 6 I E NO 139924