



**DANGER**

**Danger of electrical shock, burns or death.** Always remove all power sources before attempting any repair, service or diagnostic work. Power can be present from shore power, generator, inverter or battery. All power sources must be disabled and secured before performing any service.



**CAUTION**

If you lack the skills, tools or equipment to perform diagnostic or repair work leave such work to an authorized Winnebago Industries dealer or other qualified shop.

WIRE ASM-CHASSIS (SHT 2, D-12)

- 1-TTY 18 Y
- 2-TTZ 18 Y
- 3-ER 16 Y
- 4-UUB 16 Y
- 5-LG 18 Y
- 6-FM 14 W
- 7-LR 14 Y
- 8-HS 16 Y
- 9-WH 14 Y
- 10-KE 14 Y
- 11-LH 18 Y
- 12-LP 16 Y
- 13-LJ 16 Y
- 14-FFD/JJG 12 Y
- 15-KA 12 Y

CHASSIS BATTERY DISCONNECT LOCKOUT RELAY

- 30-UUG 18 Y
- 85-KE 14 Y
- 86-FM 14 W
- 87-
- 87A-UUB 16 Y

CHASSIS DISCONNECT POWER FUSE

- A-SJ 10 Y
- B-UUG 18 Y

COACH DISCONNECT POWER FUSE

- A-GJ 16 Y
- B-LJ 16 Y

CHASSIS ELECTRICAL BOX

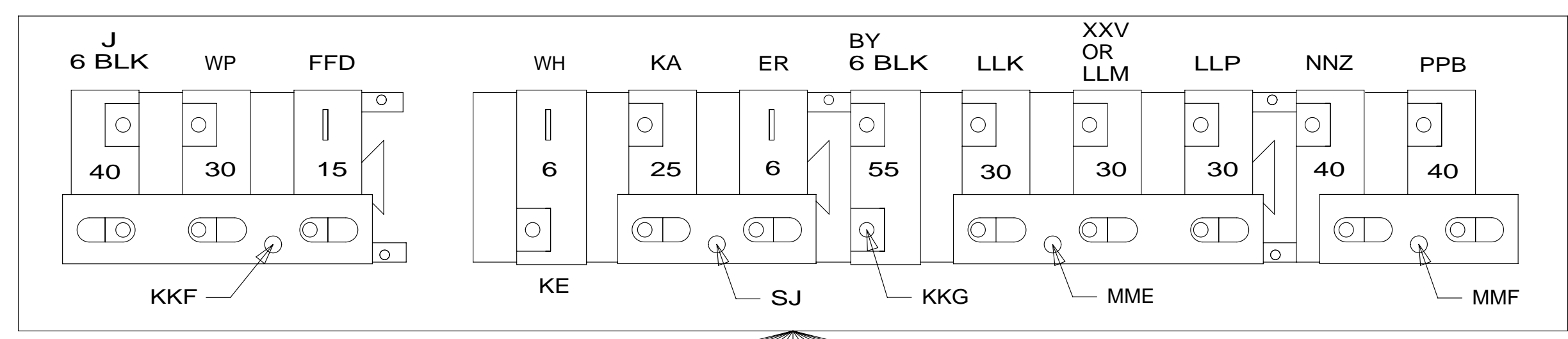

- J 6 BLK
- WP 10 Y
- FFD 12 Y
- WH 14 Y
- KA 12 Y
- ER 16 Y
- BY 6 BLK
- KKF 6 B
- KE 14 Y
- SJ 10 Y
- HS 16 Y
- GJ 16 Y

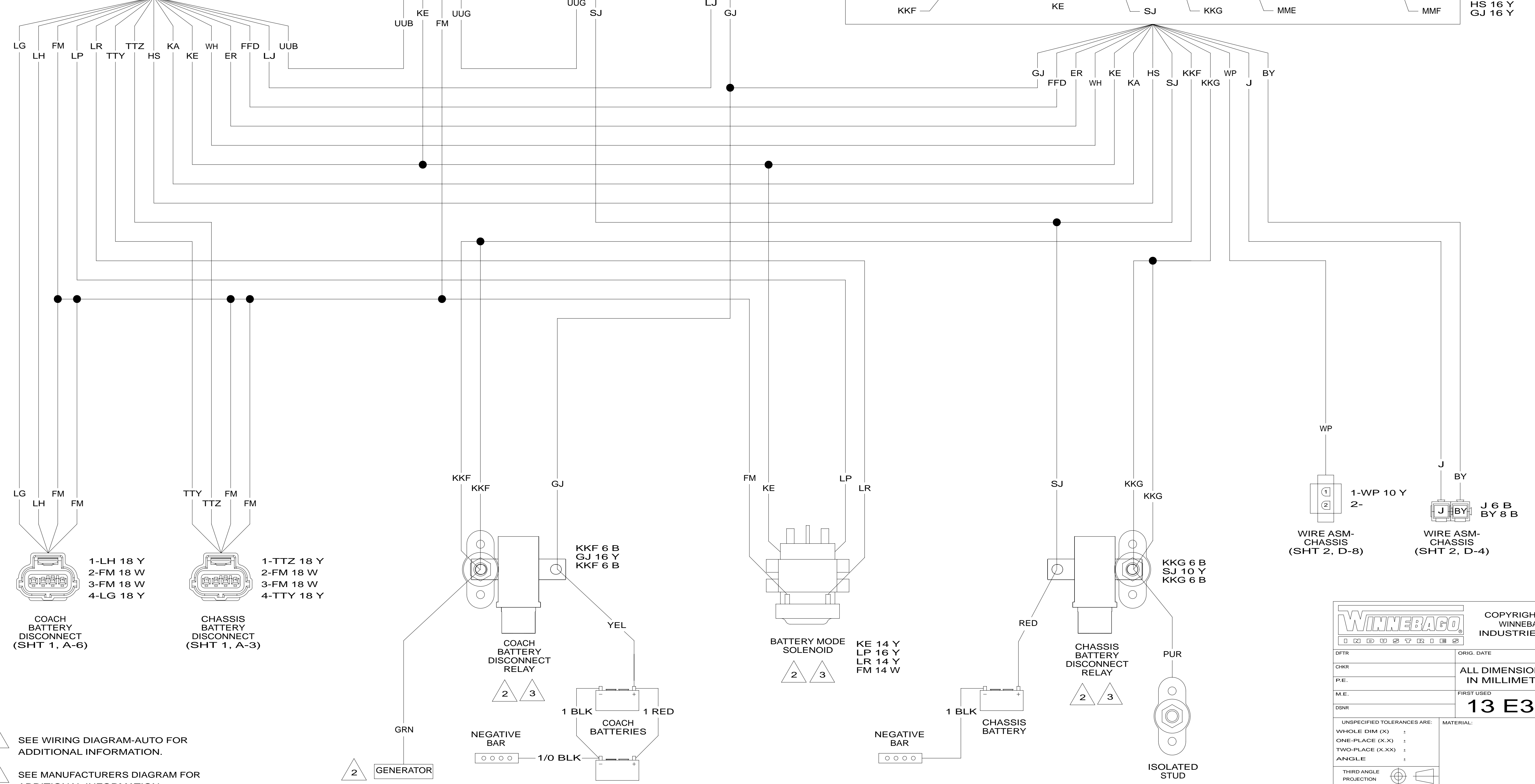

3 SEE WIRING DIAGRAM-AUTO FOR ADDITIONAL INFORMATION.

2 SEE MANUFACTURERS DIAGRAM FOR ADDITIONAL INFORMATION.

1. SPLICES ARE THEORETICAL AND MAY DIFFER IN THE HARNESS.

		COPYRIGHT 2011 WINNEBAGO INDUSTRIES, INC.	
DFT-ORIG	ORIG. DATE	ALL DIMENSIONS ARE IN MILLIMETERS	
CHKR		FIRST USED	
P.E.		13 E35F	
M.E.		MATERIAL:	
DSNR		UNSPECIFIED TOLERANCES ARE:	
DO NOT SCALE DRAWING		REFER TO ES0018 FOR FASTENER TIGHTENING GUIDELINES	
TITLE: WIRING DIAGRAM-BODY,12V			
SHEET 1 OF 14		PART NO 183959	
REF: 1		12-Sep-2012	

WIRING DIAGRAM-ELECTRICAL BOX (WIRE ASM 124125-16 REV-BT)

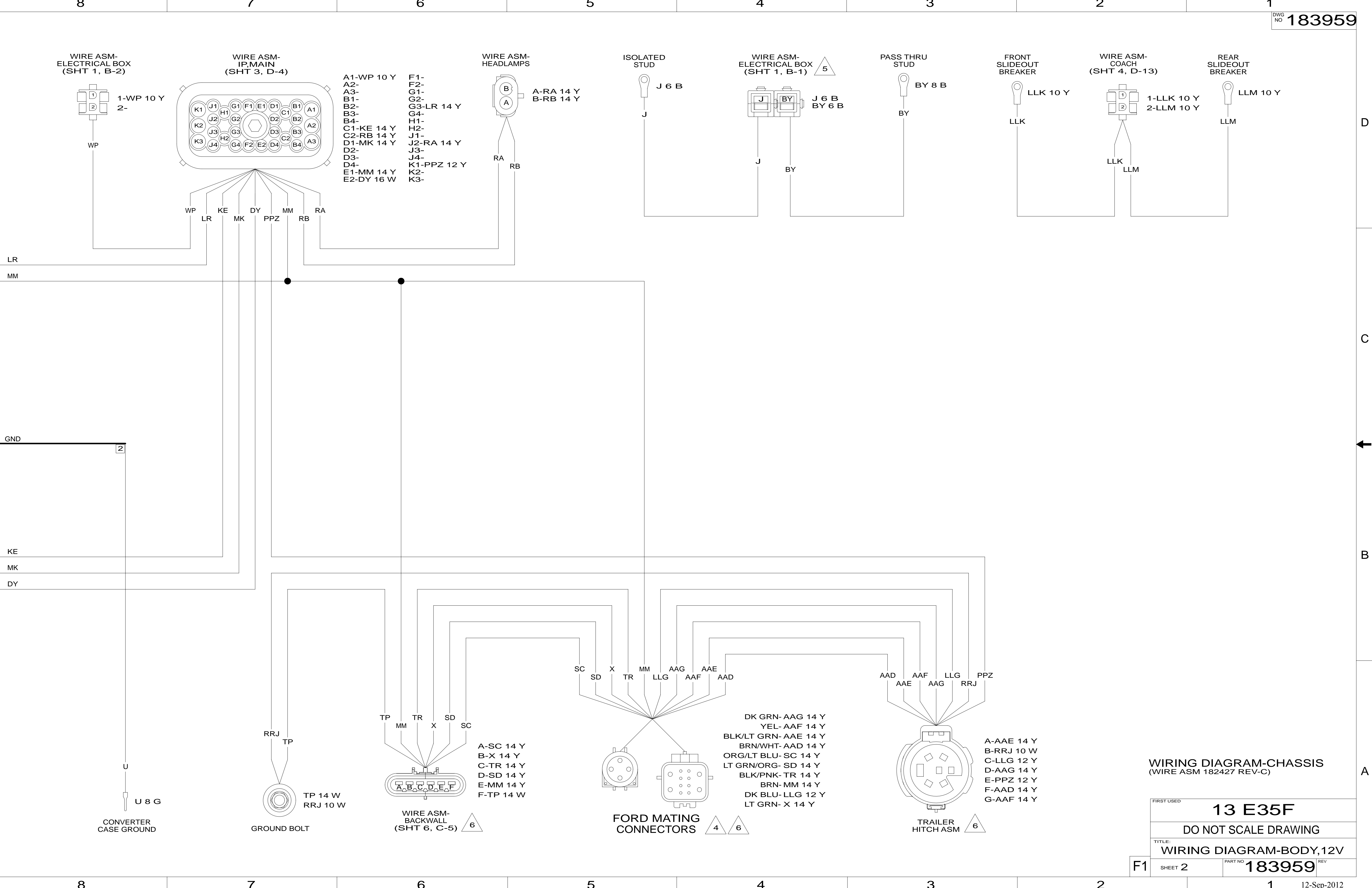

WIRING DIAGRAM-CHASSIS  
(WIRE ASM 182427 REV-C)

FIRST USED	<b>13 E35F</b>	
TITLE:	DO NOT SCALE DRAWING	
	WIRING DIAGRAM-BODY, 12V	
SHEET 2	PART NO	<b>183959</b> REV

D

C

B

A

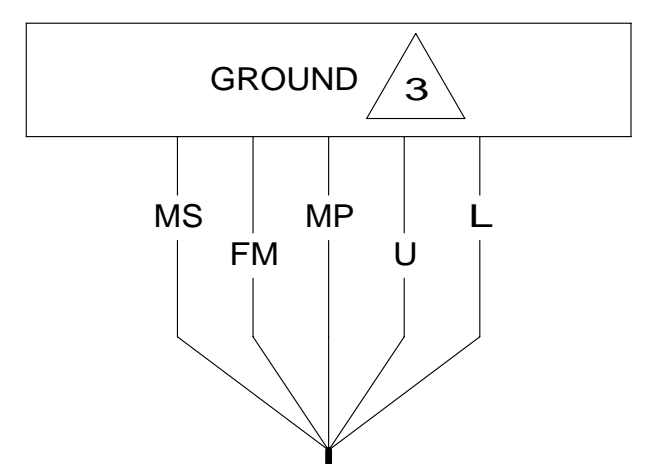

MS 14 W  
 FM 14 W  
 MP 16 W  
 U 8 G  
 L 6 G

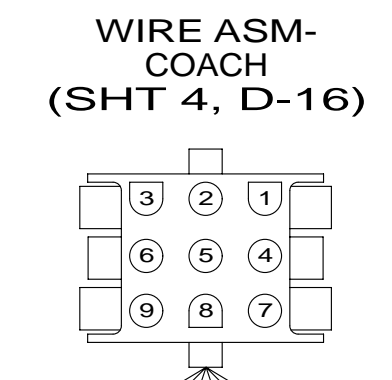

1-TTY 18 Y  
 2-TTZ 18 Y  
 3-  
 4-UUB 18 Y  
 5-  
 6-FFD 12 Y  
 7-MM 14 Y  
 8-MS 14 W

MS MM FFD UUB TTZ TTY

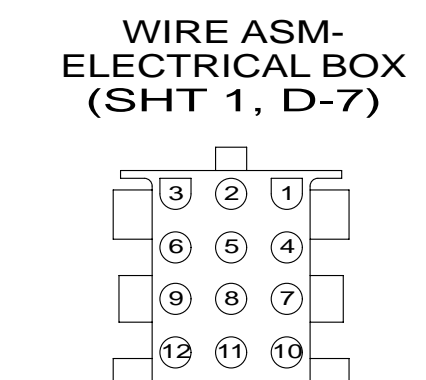

1-TTY 18 Y  
 2-TTZ 18 Y  
 3-ER 16 Y  
 4-UUB 18 Y  
 5-LG 18 Y  
 6-FM 14 W  
 7-LR 14 Y  
 8-  
 9-WH 14 Y  
 10-KE 14 Y  
 11-LH 18 Y  
 12-  
 13-LJ 18 Y  
 14-FFD 12 Y  
 15-KA 12 Y

TTY TTZ UUB FFD LG LH LJ ER KE FM LR WH KA

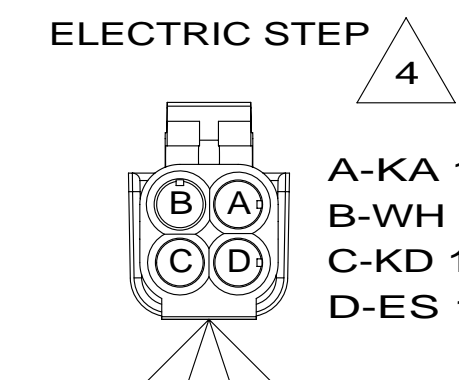

A-KA 12 Y  
 B-WH 14 Y  
 C-KD 18 W  
 D-ES 16 Y

KA WH ES KD

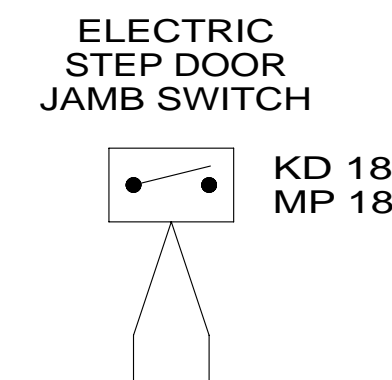

KD 18 W  
 MP 18 W

KD MP

2

2

2

2

GND

LG LH LJ ER ES KE MK DY JT LP LL LM LN

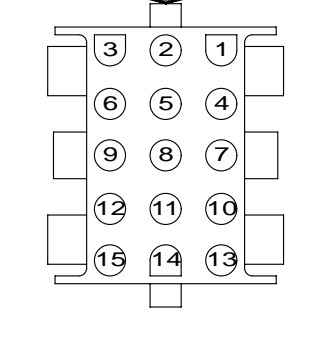

1-ER 16 Y  
 2-ES 16 Y  
 3-JT 16 Y  
 4-LN 16 W  
 5-LM 16 W  
 6-LL 16 W  
 7-LP 16 Y  
 8-KE 14 Y  
 9-DY 16 W  
 10-  
 11-  
 12-LG 18 Y  
 13-LH 18 Y  
 14-LJ 18 Y  
 15-MK 14 Y

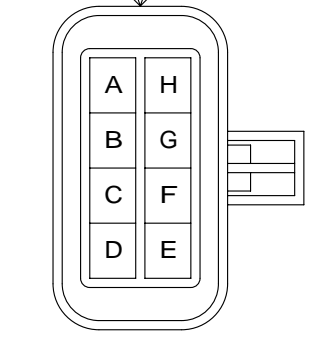

A-LN 16 W  
 B-LM 16 W  
 C-LL 16 W  
 D-  
 E-LP 16 Y  
 F-  
 G-  
 H-

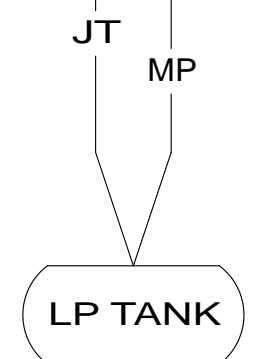

JT 16 W  
 MP 16 W

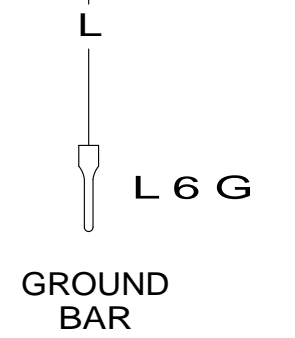

L 6 G

6 SEE WIRING DIAGRAM-AUTO LAMPS FOR ADDITIONAL INFORMATION.

5 SEE WIRING DIAGRAM-AUTO FOR ADDITIONAL INFORMATION.

4 SEE MANUFACTURERS DIAGRAM FOR ADDITIONAL INFORMATION.

3 GROUNDS ARE SHOWN AS A SINGLE LINE FOR EASE IN TRACING. EACH GROUND CIRCUIT IS SEPERATE IN THE HARNESS.

2 NOT A SPLICE POINT. INDICATES ENTRY INTO WIRING HARNESS.

1. SPLICES ARE THEORETICAL AND MAY DIFFER IN THE HARNESS.

NOTES:

8

7

6

5

4

3

2

1

FORD WIRE ASM-MAIN

- LT BLU/WHT -
- BRN/LT BLU -
- RED/PNK -
- DK GRN/ORG -
- BLK/LT BLU -
- LT GRN -
- WHT/PUR - LD 14 Y
- BLK/LT GRN - TR 14 Y
- YEL/BLK -
- BRN/PUR - MK 14 Y
- LT GRN/RED - DY 16 W
- LT BLU/RED - ML 16 Y
- ORG/LT GRN - MN 14 W
- BRN - MM 14 Y
- WHT/LT BLU - KE 14 Y
- RED/YEL - FU 14 Y

GROUND STUD



WIRE ASM-CLEARANCE LAMPS (SHT 7, A-6)

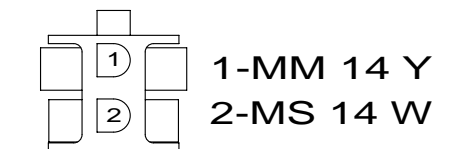

WIRE ASM-CHASSIS (SHT 2, D-7)

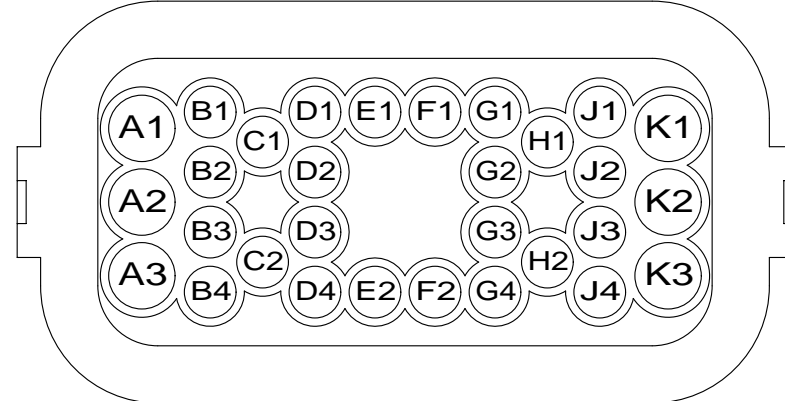

- A1-WP 10 Y
- A2-
- A3-
- B1-
- B2-
- B3-
- B4-
- C1-KE 14 Y
- C2-RB 14 Y
- D1-MK 14 Y
- D2-
- D3-
- D4-
- E1-MM 14 Y
- E2-DY 16 W

- F1-
- F2-
- G1-
- G2-
- G3-LR 14 Y
- G4-
- H1-
- H2-
- J1-
- J2-RA 14 Y
- J3-
- J4-
- K1-PPZ 12 Y
- K2-
- K3-

WIRE ASM-REAR MONITOR

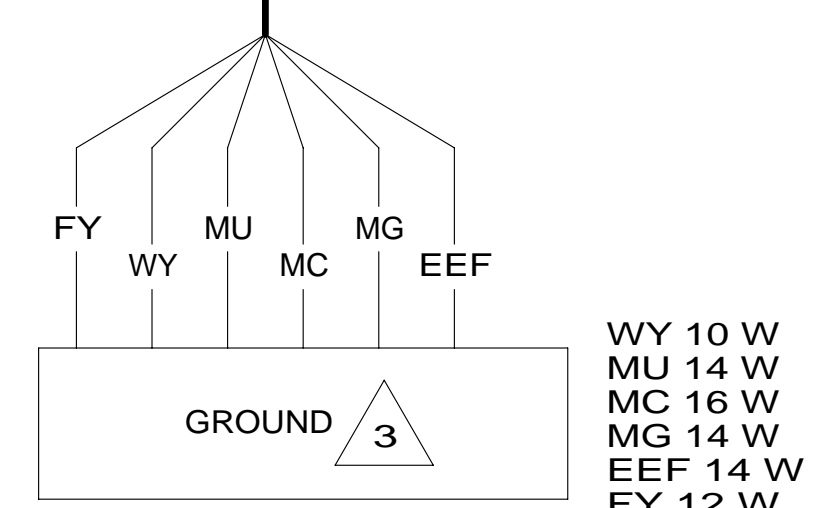
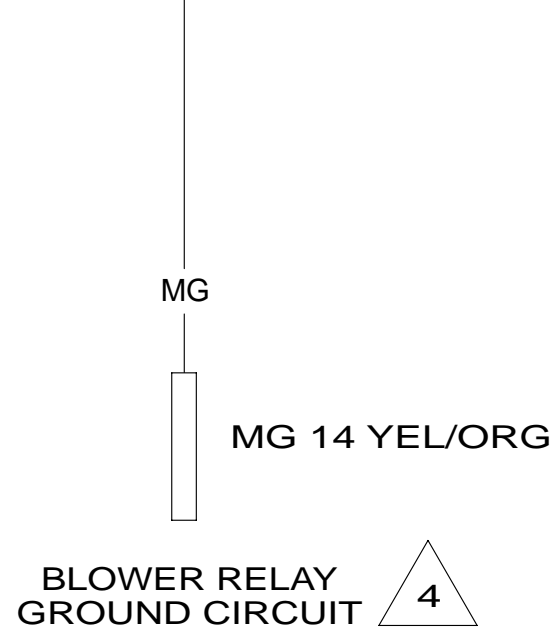
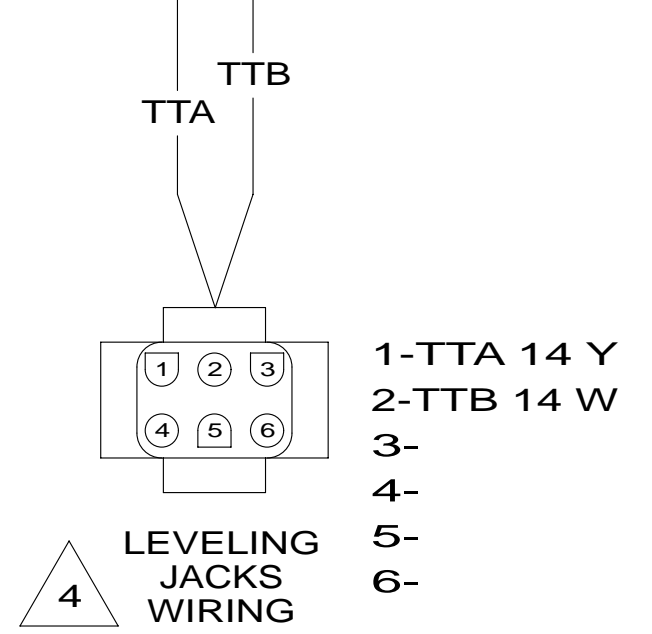
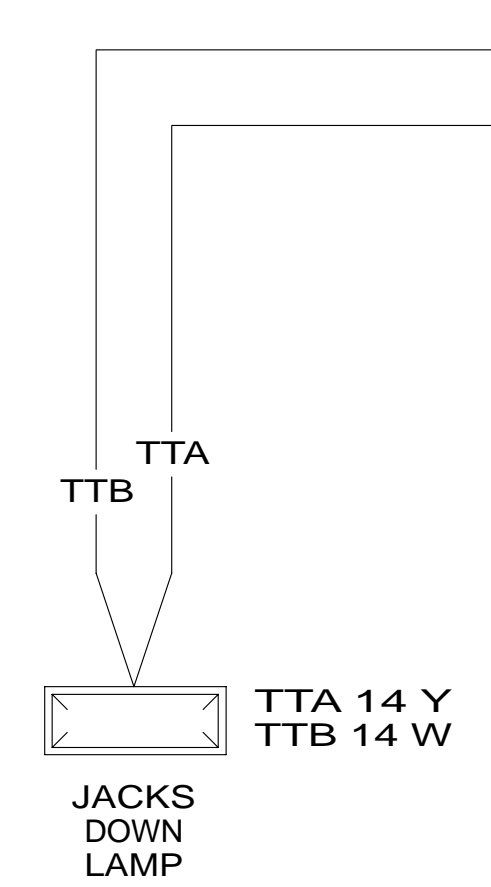
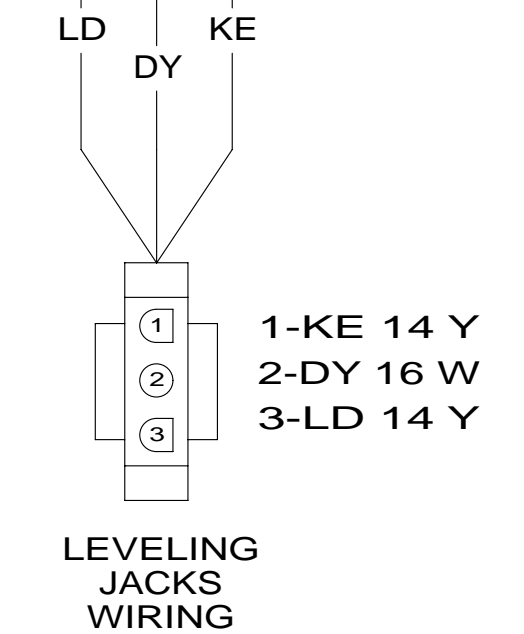
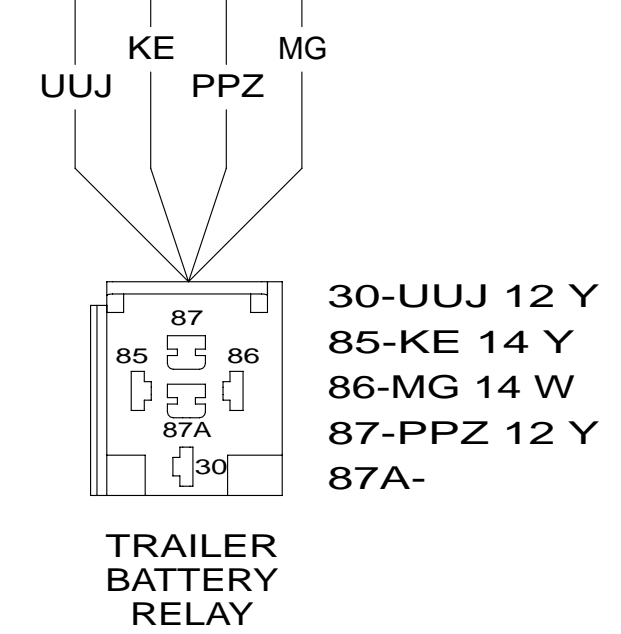
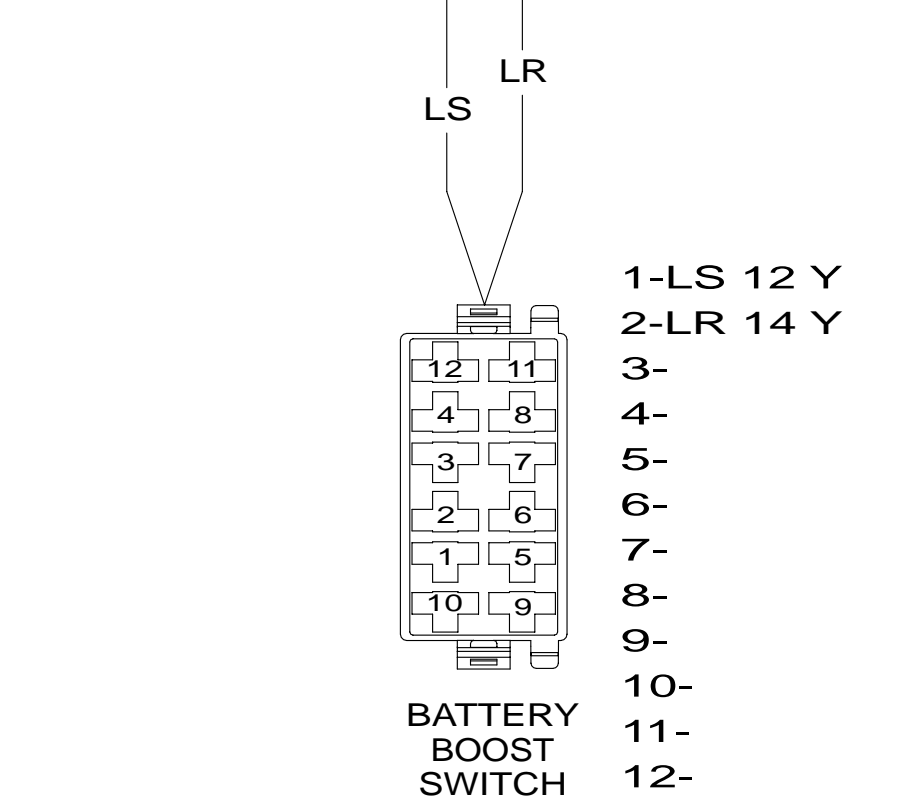
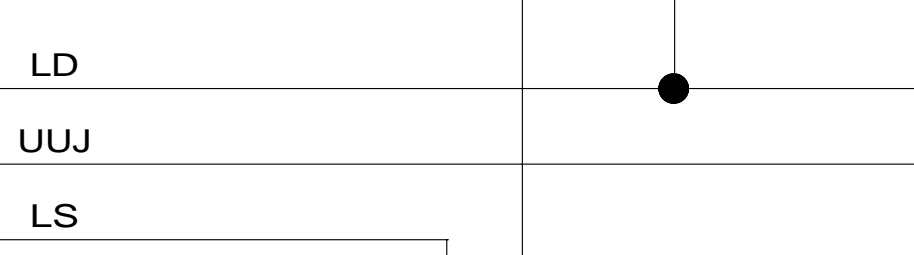
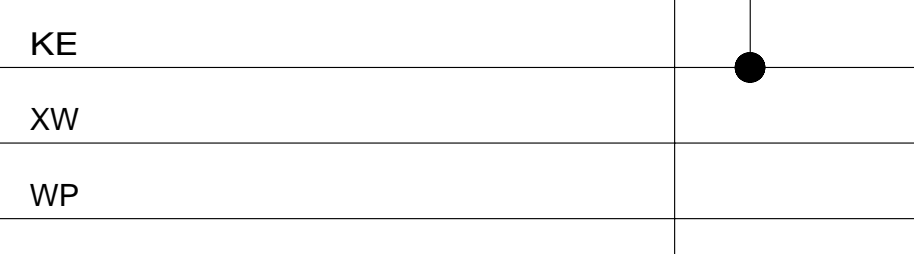
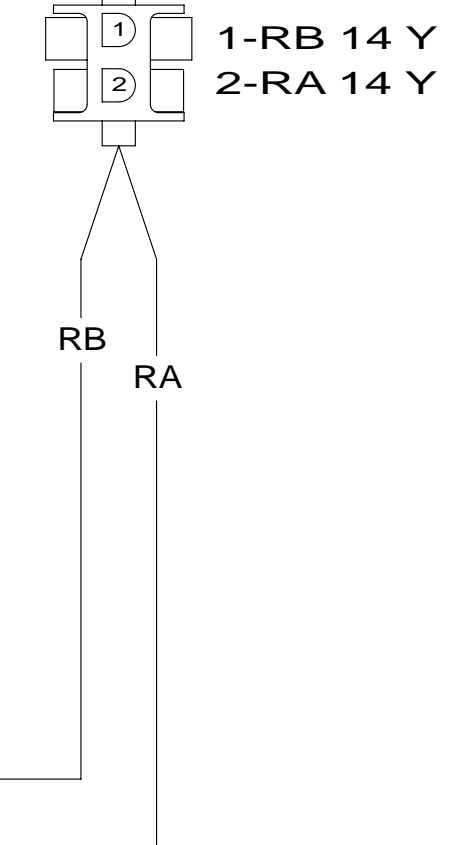
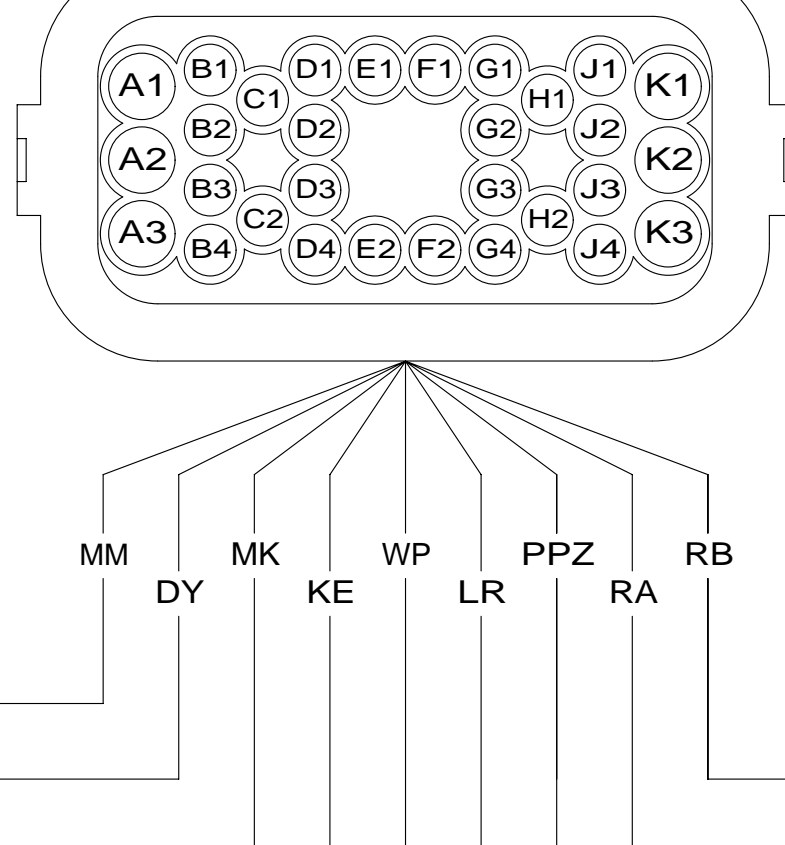
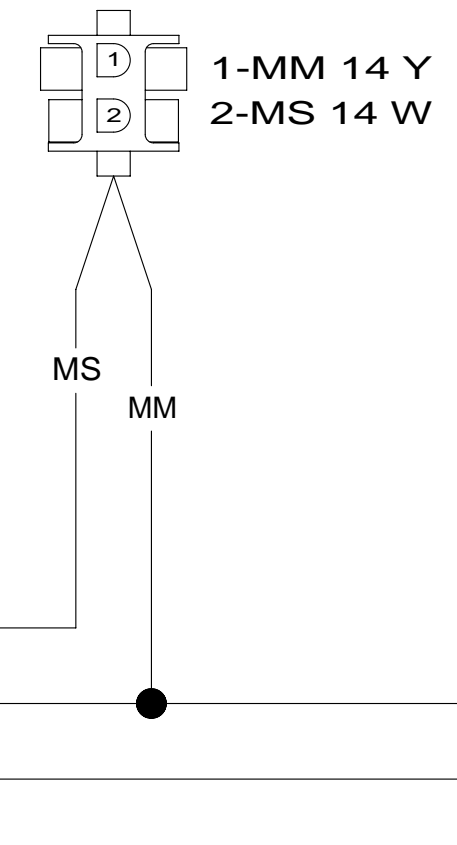
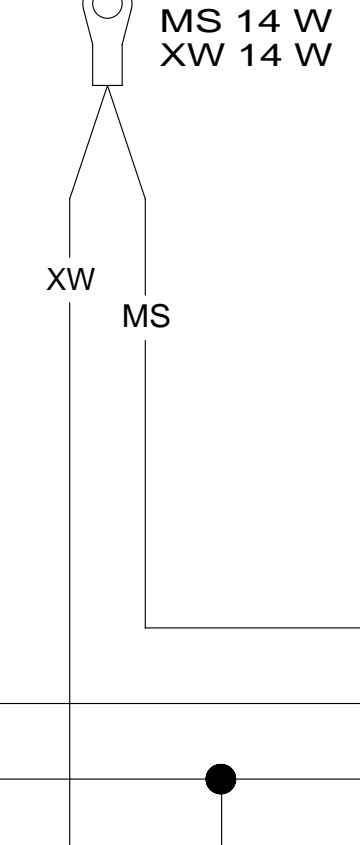
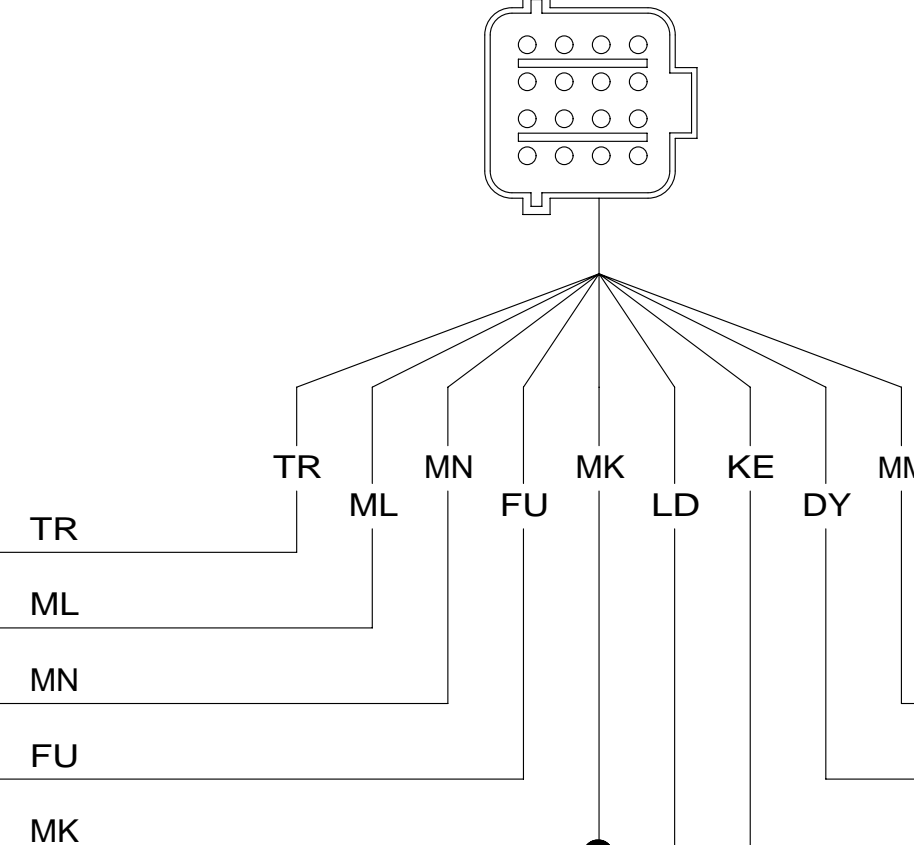
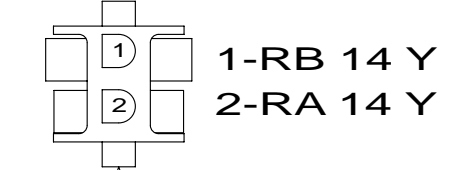

DIODE (BUILT INTO HARNESS)

WIRING DIAGRAM-IP,MAIN (WIRE ASM 181071 REV-E)

FIRST USED 13 E35F

DO NOT SCALE DRAWING

TITLE: WIRING DIAGRAM-BODY,12V

SHEET 3 PART NO 183959 REV

8

7

6

5

4

3

2

1

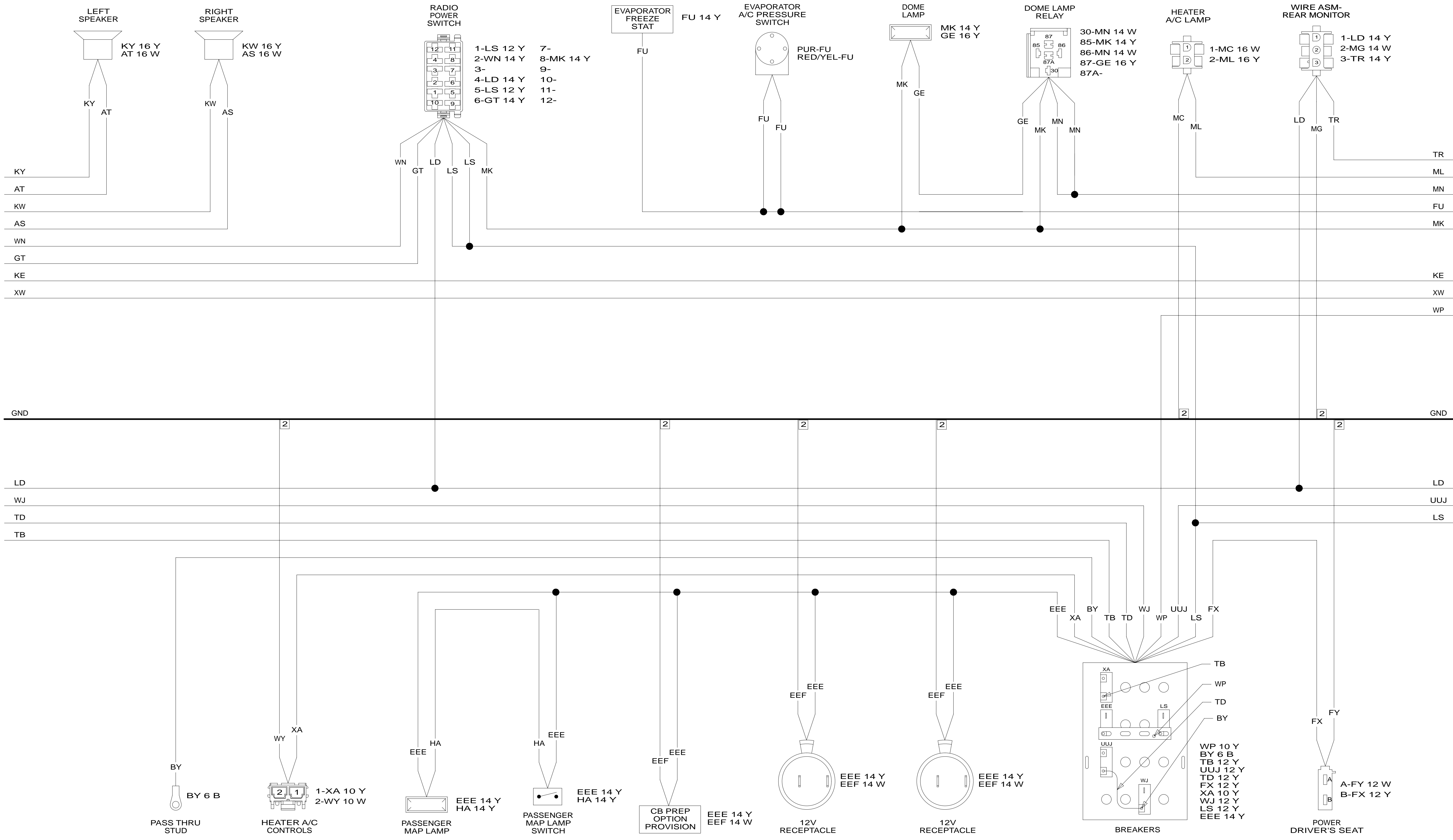

D

C

B

A

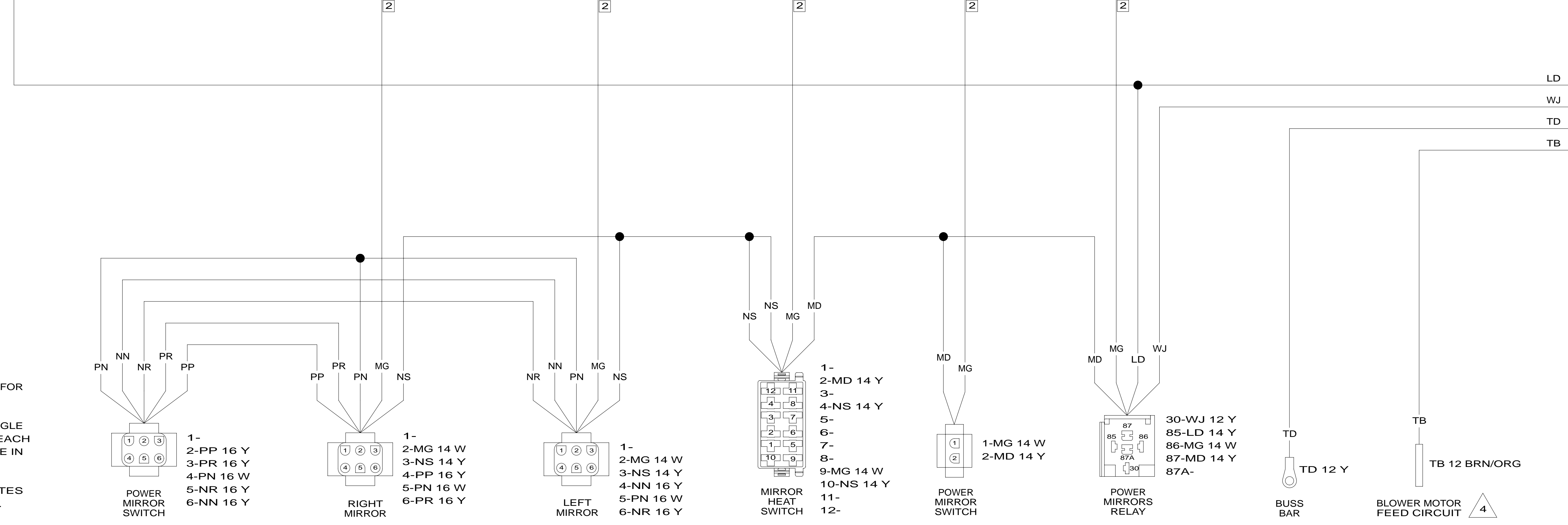
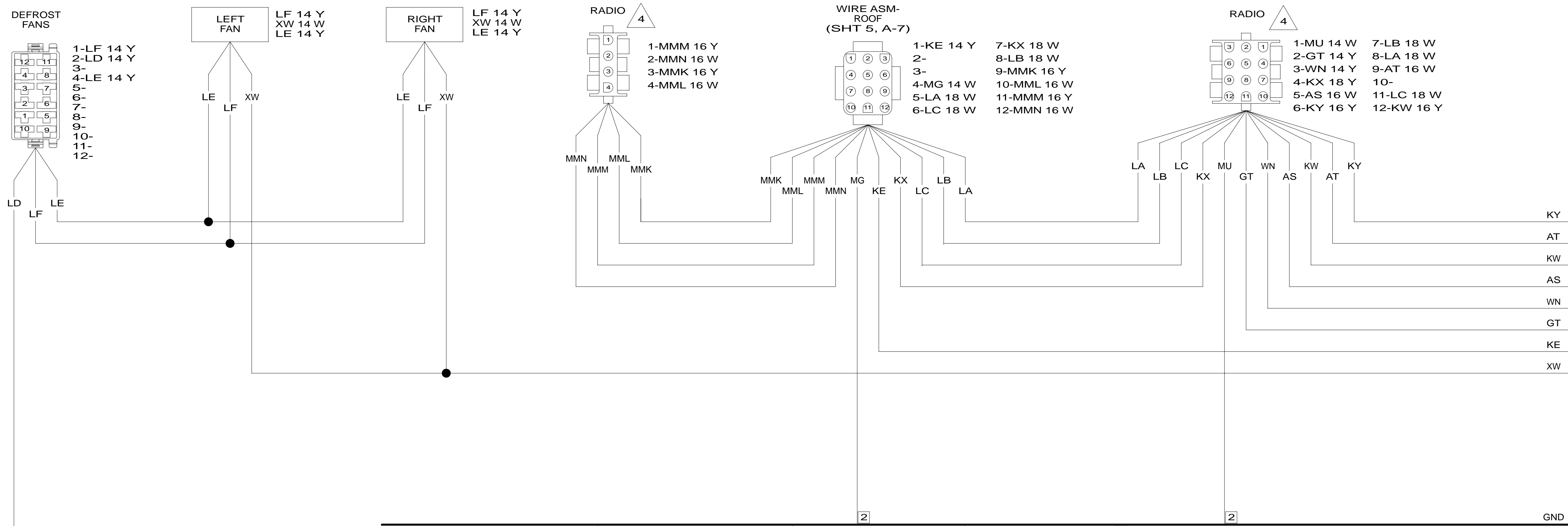

- 4 SEE MANUFACTURERS DIAGRAM FOR ADDITIONAL INFORMATION.
  - 3 GROUNDS ARE SHOWN AS A SINGLE LINE FOR EASE IN TRACING. EACH GROUND CIRCUIT IS SEPERATE IN THE HARNESS.
  - 2 NOT A SPLICE POINT. INDICATES ENTRY INTO WIRING HARNESS.
1. SPLICES ARE THEORETICAL AND MAY DIFFER IN THE HARNESS.

NOTES:

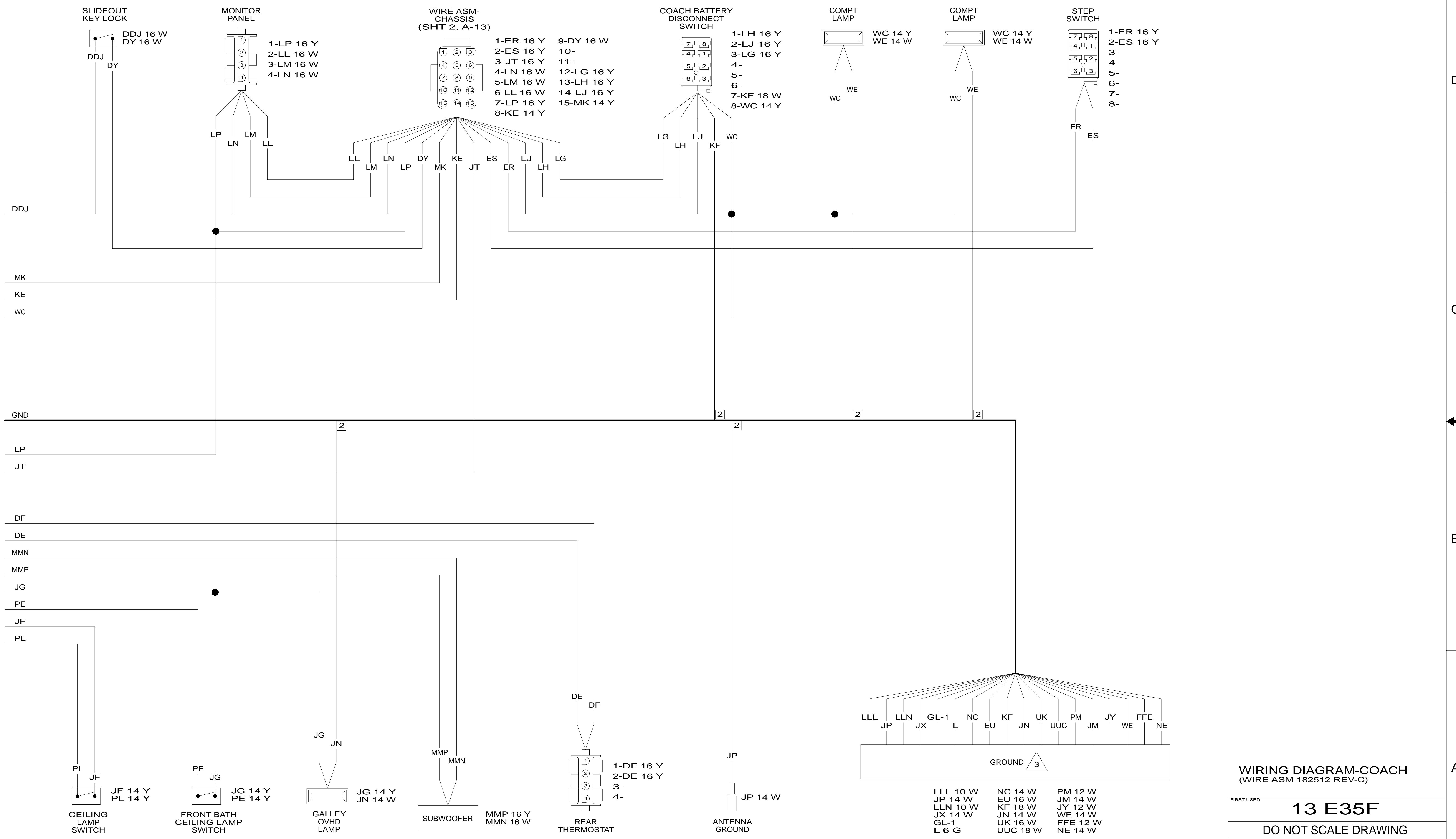

D

C

B

A



WIRE ASM-CHASSIS (SHT 2, D-13)

- 1-TTY 18 Y
- 2-TTZ 18 Y
- 3-
- 4-UUB 18 Y
- 5-
- 6-FFD 12 Y
- 7-MM 14 Y
- 8-MS 14 W
- 9-

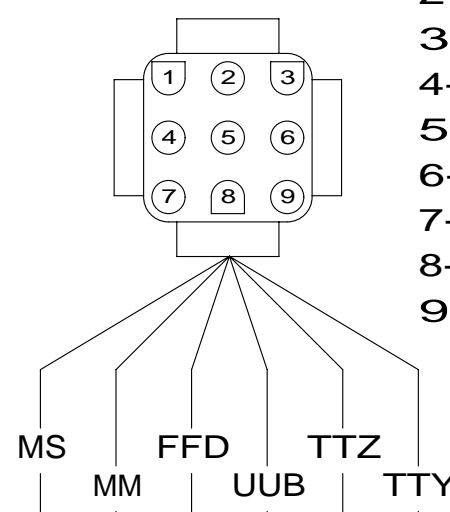

CHASSIS BATTERY DISCONNECT SWITCH

- 1-TTZ 18 Y
- 2-UUB 18 Y
- 3-TTY 18 Y
- 4-
- 5-
- 6-
- 7-UUC 18 W
- 8-MK 14 Y

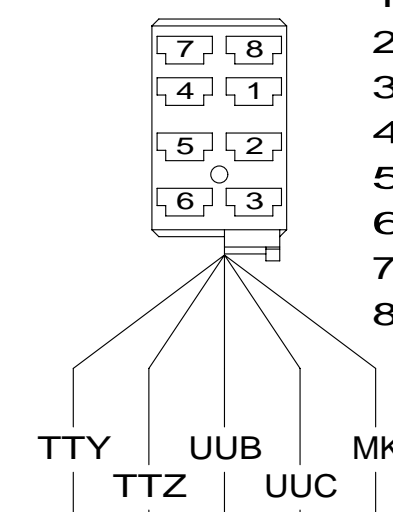

SLIDEOUT RELAY

- 30-MK 14 Y
- 85-MK 14 Y
- 86-BBA 16 W
- 87-DT 16 Y
- 87A-

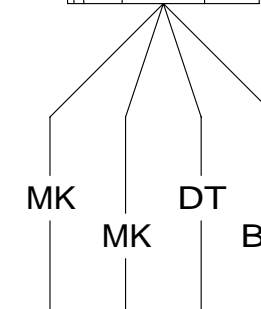

WIRE ASM-CHASSIS (SHT 2, D-2)

- 1-LLK 10 Y
- 2-LLM 10 Y

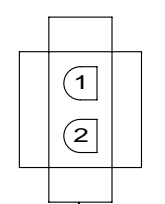

LEFT SLIDEROOM CONTROLLER

- LLK 10 Y
- LLL 10 W
- DR 16 Y
- DU 16 Y

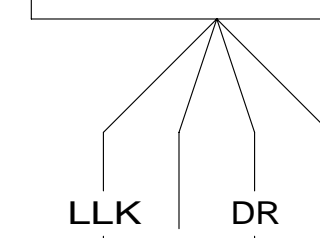

LEFT FRONT SLIDEOUT LOCK SWITCH

- 1-DU 16 Y
- 2-DT 16 Y
- 3-DR 16 Y
- 4-BBA 16 W
- 5-DDJ 16 W
- 6-BBA 16 W
- 7-
- 8-

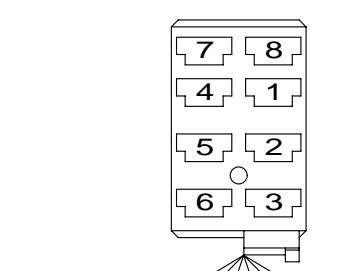

RIGHT SLIDEROOM CONTROLLER

- LLM 16 Y
- LLN 10 W
- BBM 16 Y

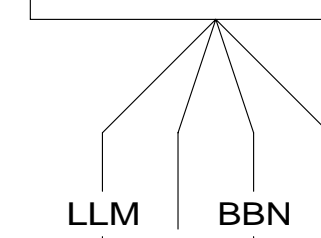

RIGHT REAR SLIDEOUT SWITCH

- 1-BBN 16 Y
- 2-DT 16 Y
- 3-BBM 16 Y
- 4-BBA 16 W
- 5-DDJ 16 W
- 6-BBA 16 W
- 7-
- 8-

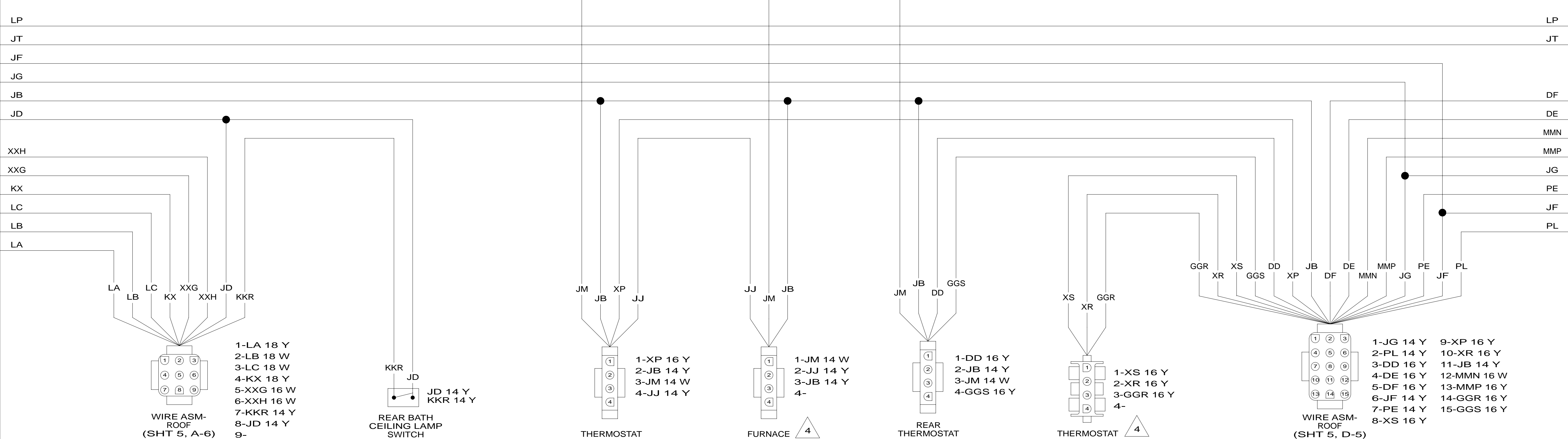
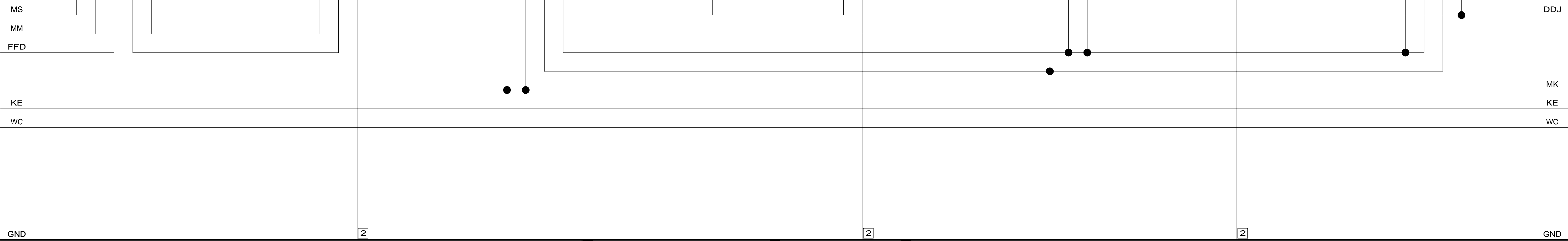
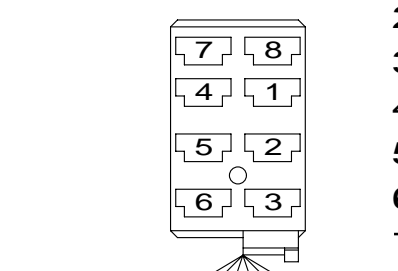

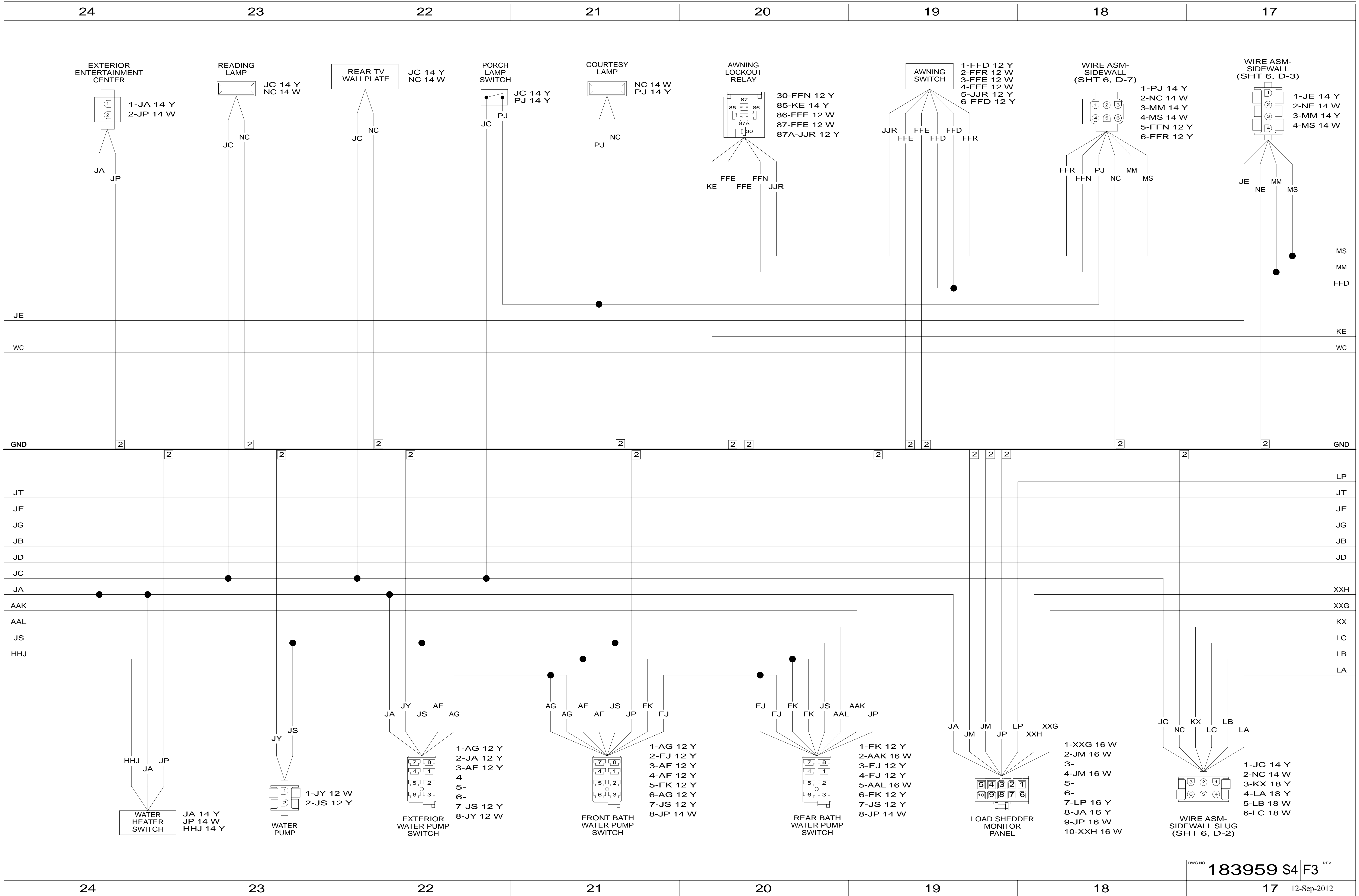

D

C

B

A

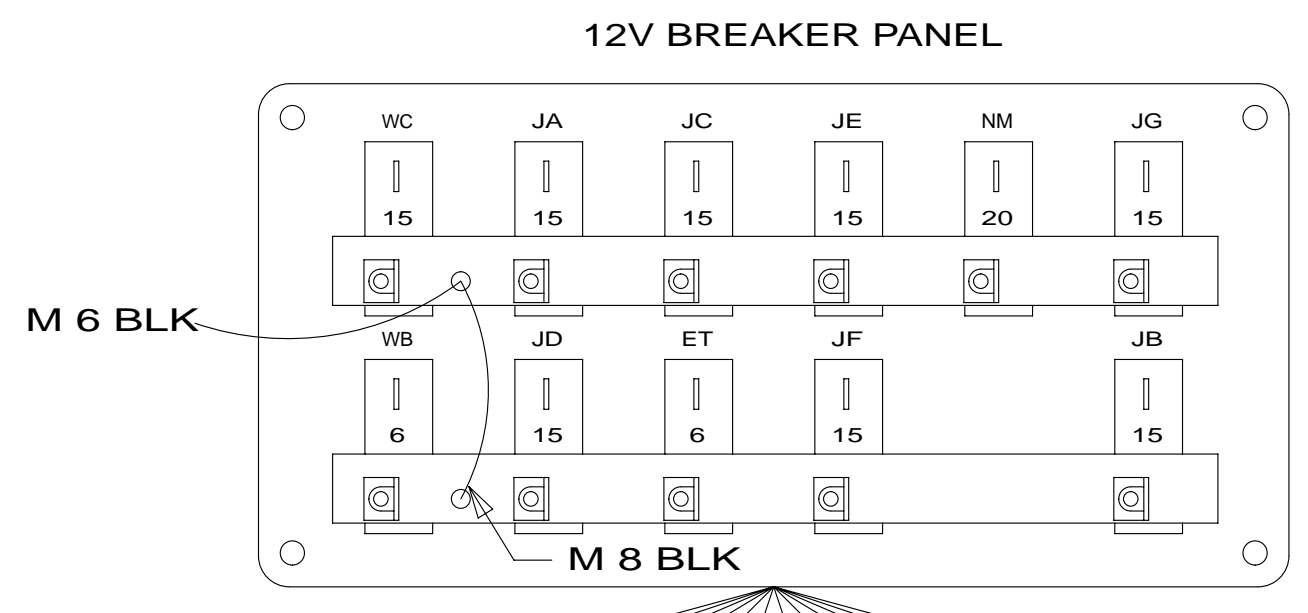

- M 6 B
- JA 12 Y
- NM 12 Y
- JB 14 Y
- JC 14 Y
- JD 14 Y
- JE 14 Y
- JF 14 Y
- JG 14 Y
- WC 14 Y
- WB 16 Y
- ET 16 Y



- ET 16 Y
- EU 16 W

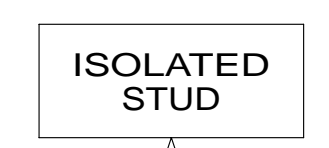

- K 6 B
- M 6 B



- K 6 B
- L 6 G



- 1-DA 12 Y
- 2-NM 12 Y
- 3-
- 4-
- 5-
- 6-
- 7-
- 8-

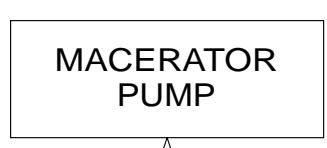

- DA 12 Y
- PM 12 W



- WB 16 Y

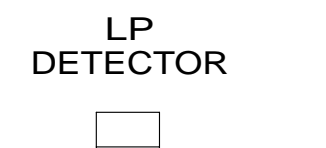

- 1-UK 16 W
- 2-
- 3-WB 16 Y

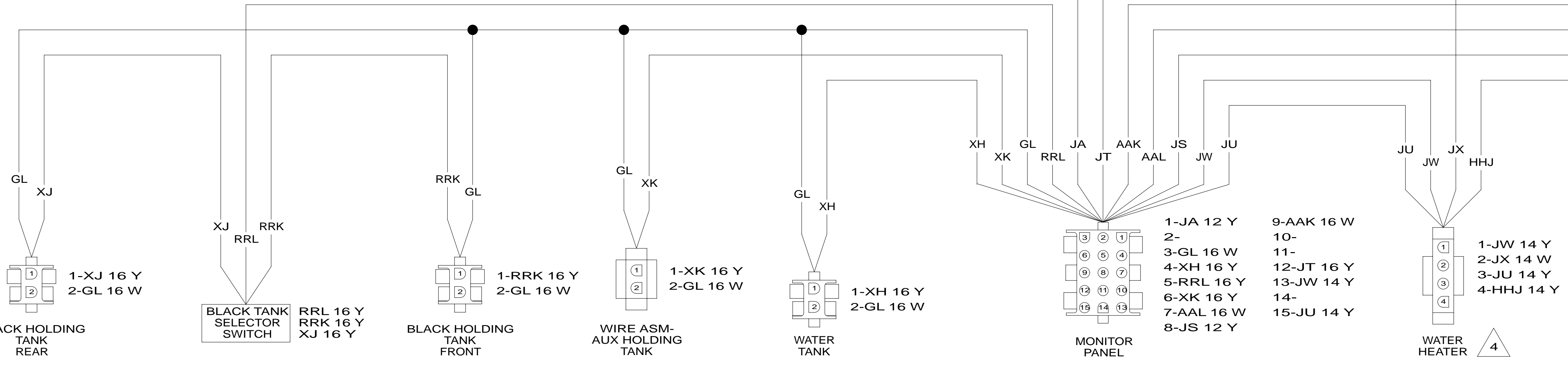
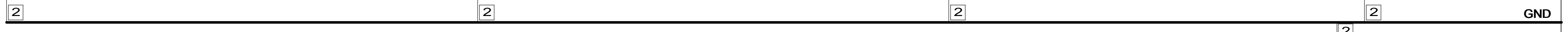

- 4 SEE MANUFACTURERS DIAGRAM FOR ADDITIONAL INFORMATION.
  - 3 GROUNDS ARE SHOWN AS A SINGLE LINE FOR EASE IN TRACING. EACH GROUND CIRCUIT IS SEPERATE IN THE HARNESS.
  - 2 NOT A SPLICE POINT. INDICATES ENTRY INTO WIRING HARNESS.
1. SPLICES ARE THEORETICAL AND MAY DIFFER IN THE HARNESS.

NOTES:

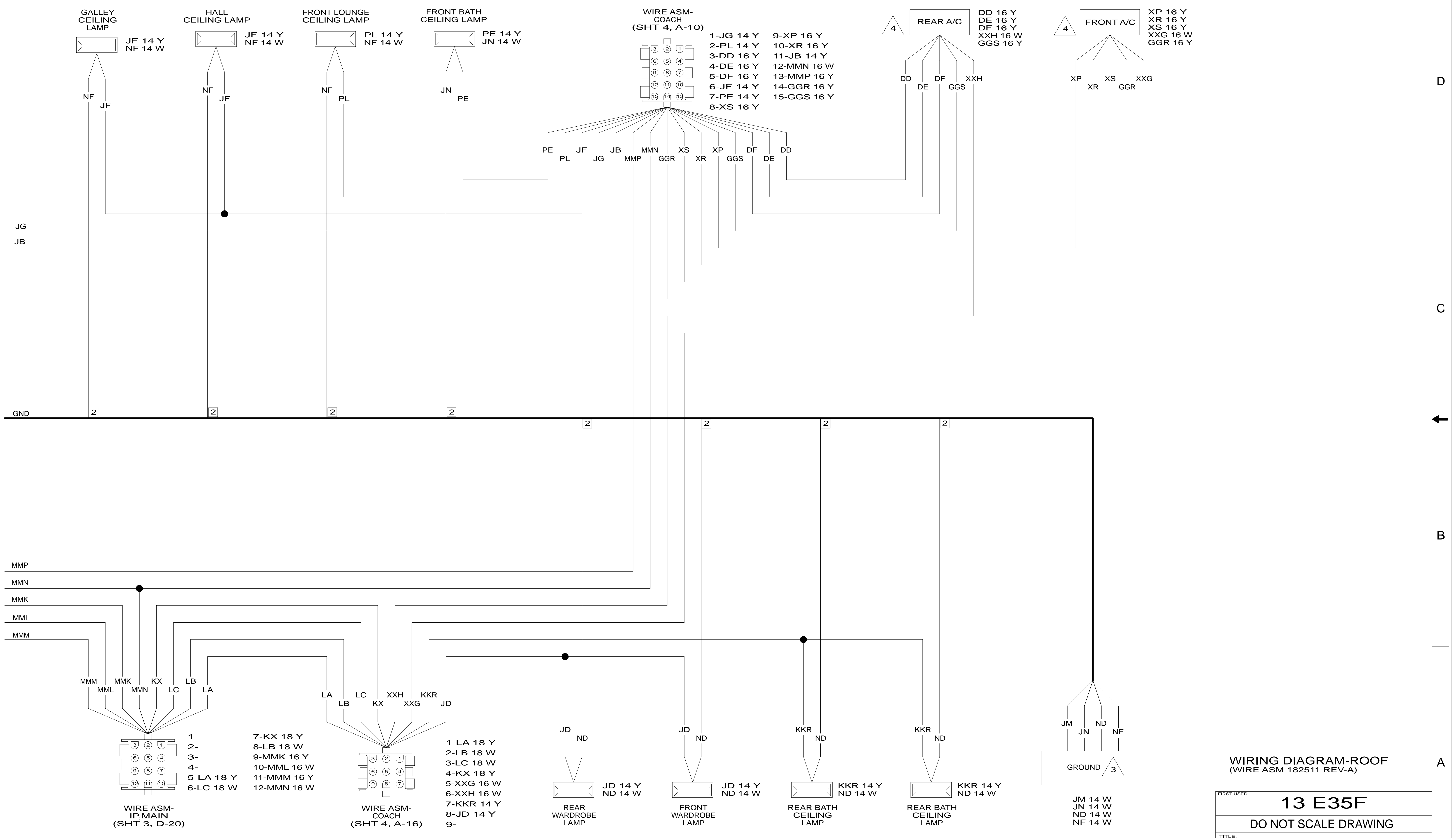

WIRING DIAGRAM-ROOF  
(WIRE ASM 182511 REV-A)

FIRST USED **13 E35F**

DO NOT SCALE DRAWING

TITLE: **WIRING DIAGRAM-BODY, 12V**

SHEET 5 PART NO **183959** REV

16

15

14

13

12

11

10

9

D

C

B

A

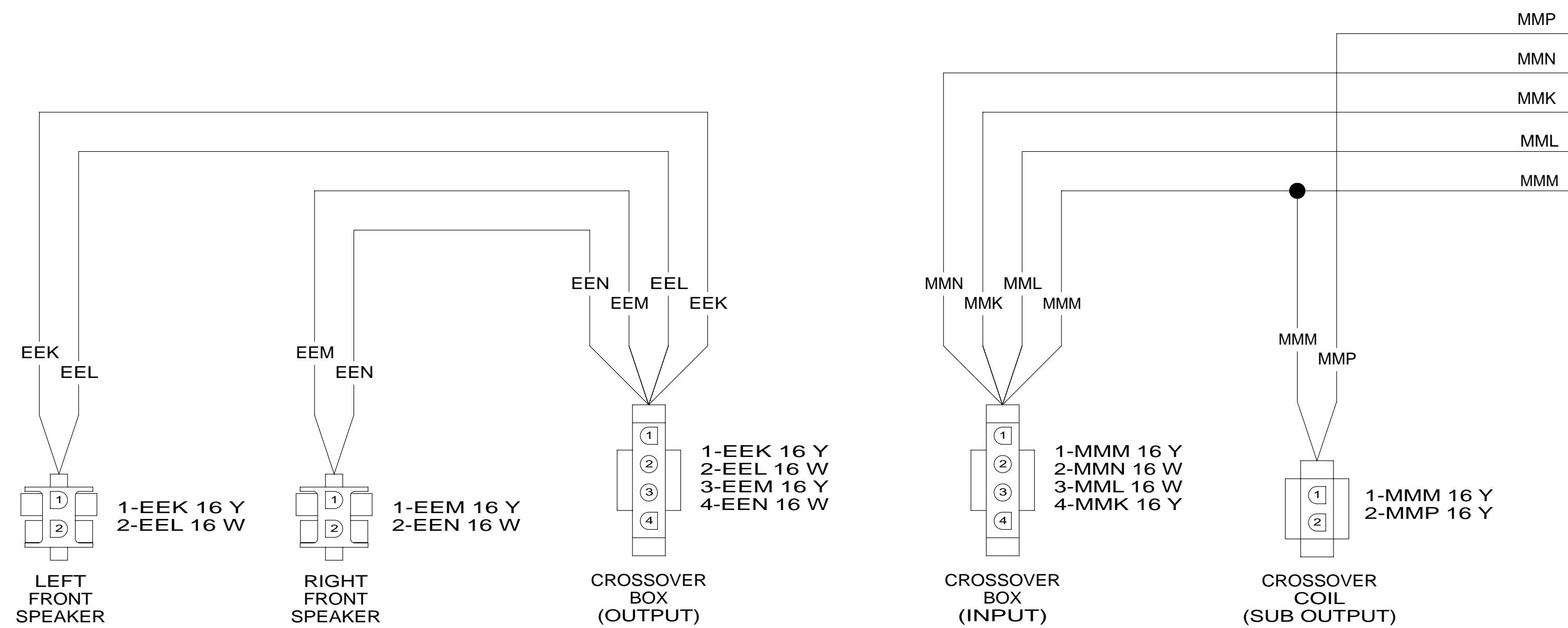
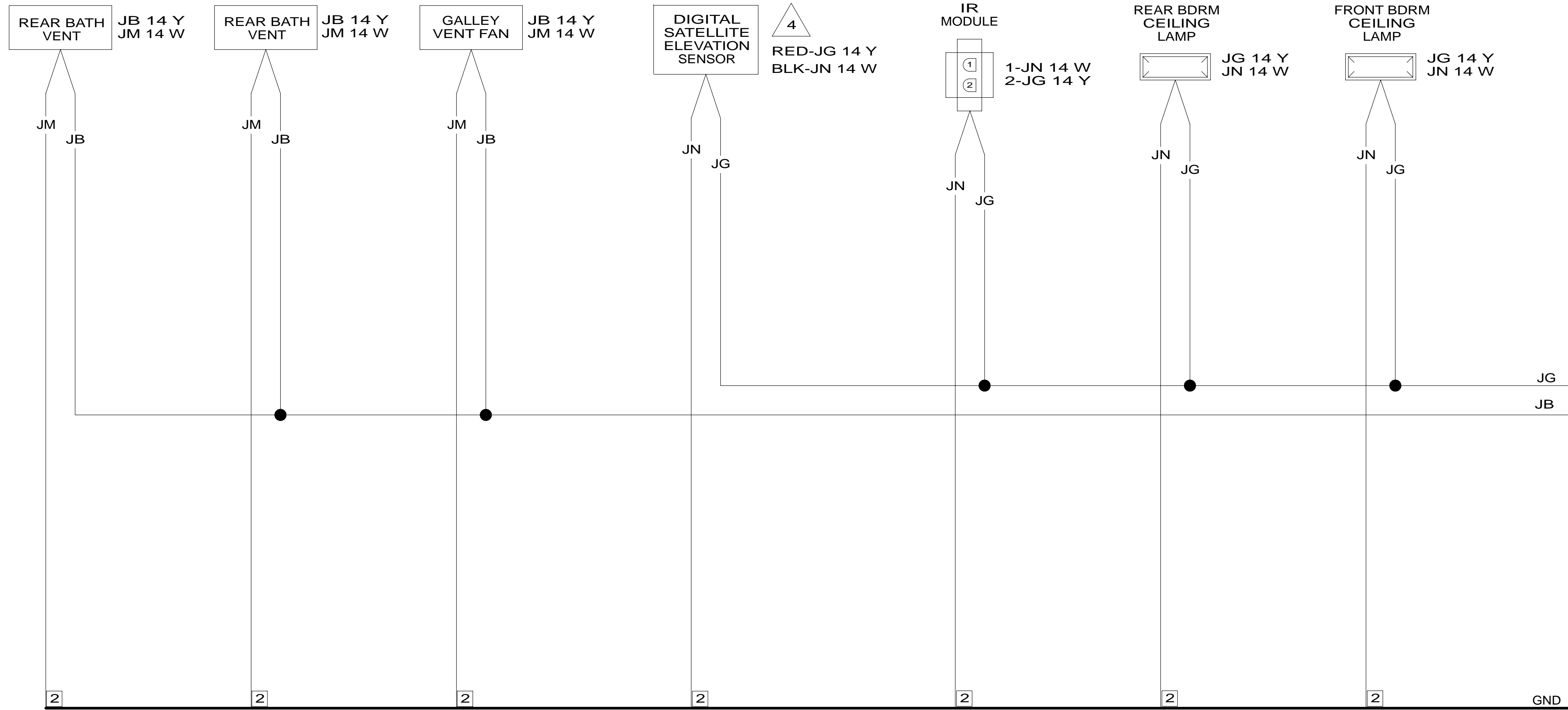

4 SEE MANUFACTURERS DIAGRAM FOR ADDITIONAL INFORMATION.

3 GROUNDS ARE SHOWN AS A SINGLE LINE FOR EASE IN TRACING. EACH GROUND CIRCUIT IS SEPERATE IN THE HARNESS.

2 NOT A SPLICE POINT. INDICATES ENTRY INTO WIRING HARNESS.

1. SPLICES ARE THEORETICAL AND MAY DIFFER IN THE HARNESS.

NOTES:

16

15

14

13

12

11

10

9

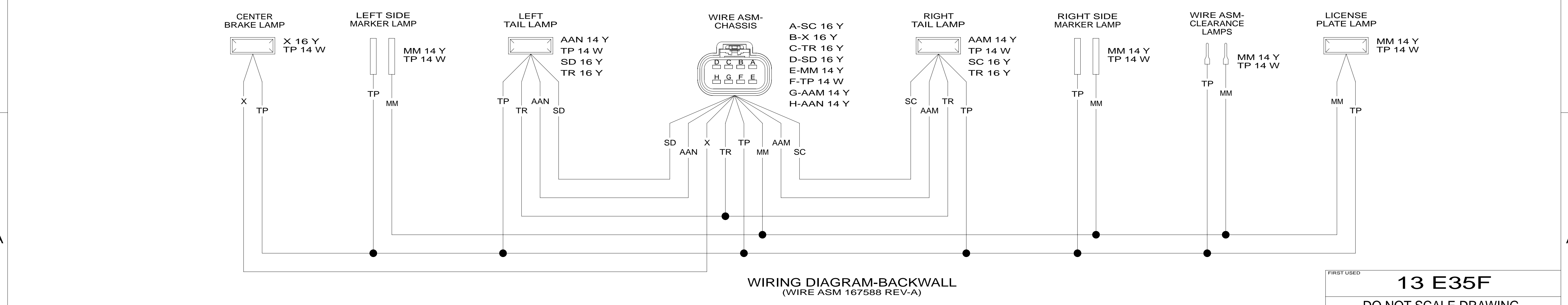
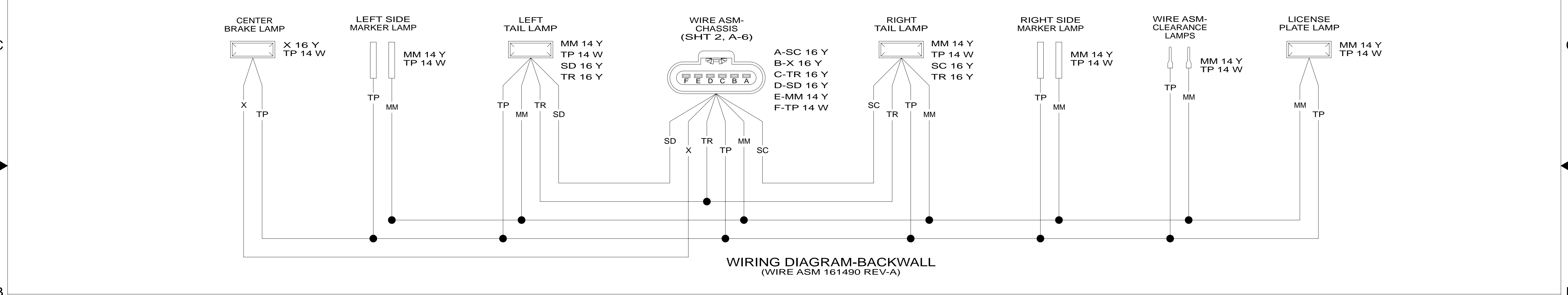
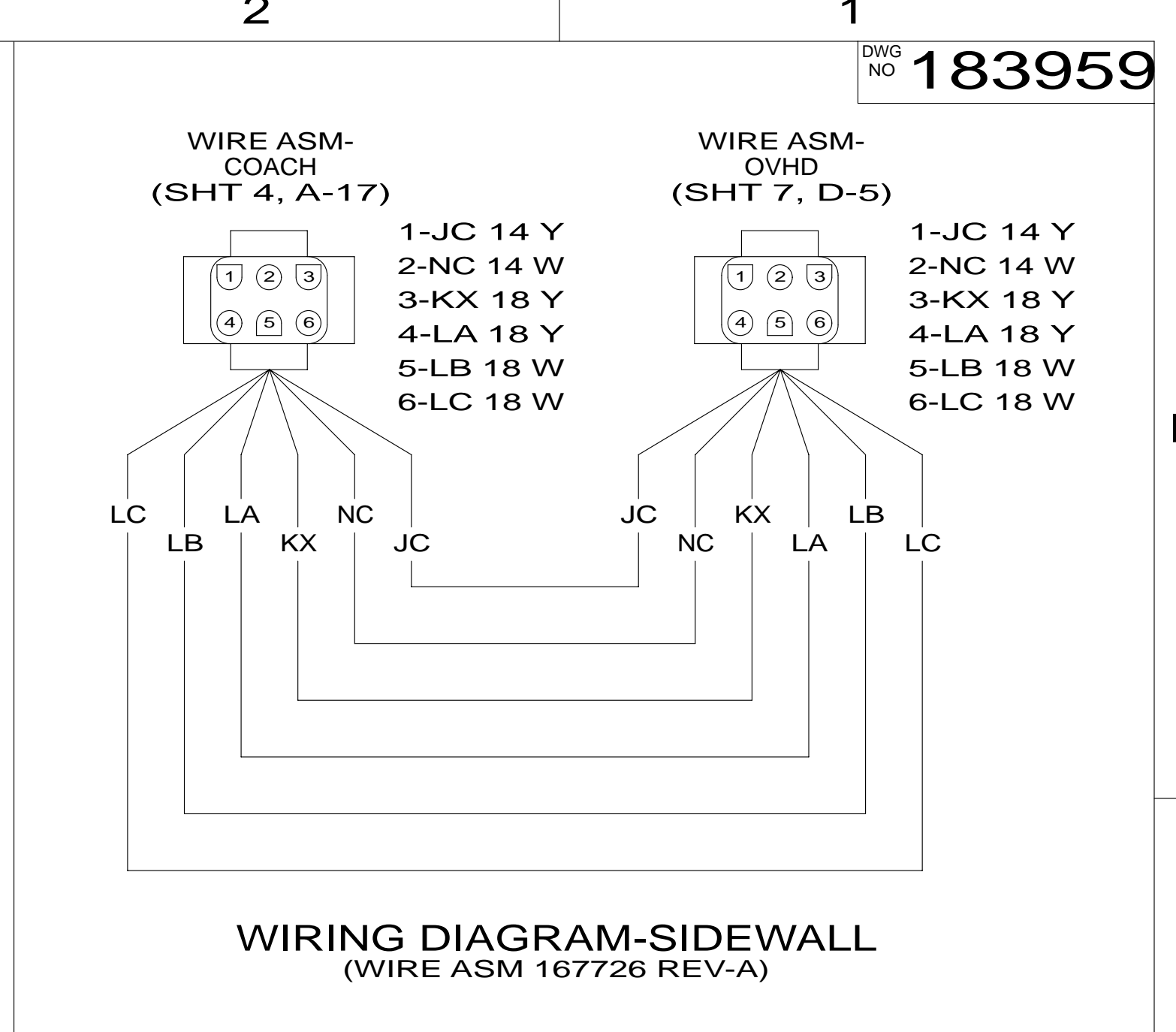
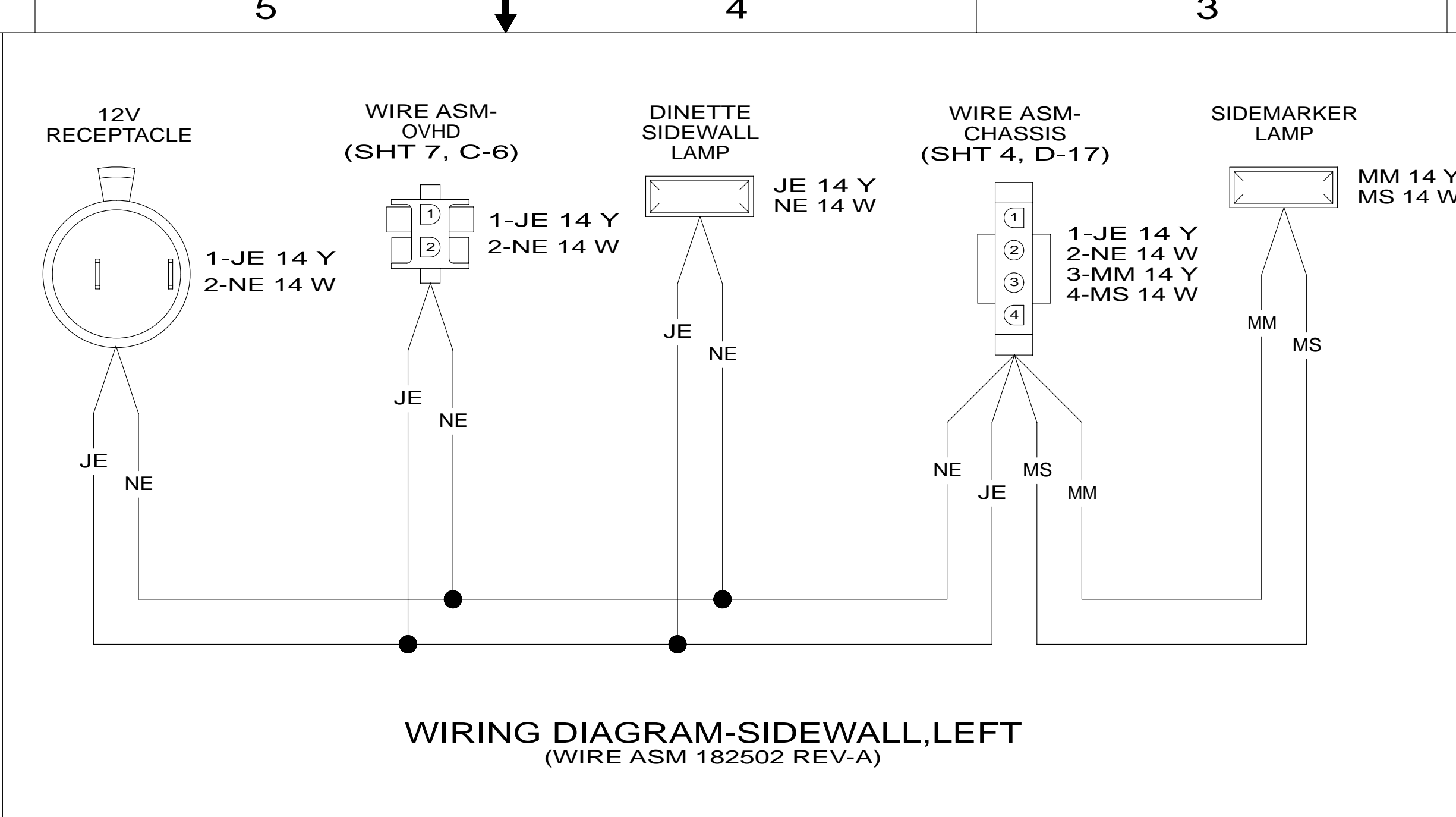
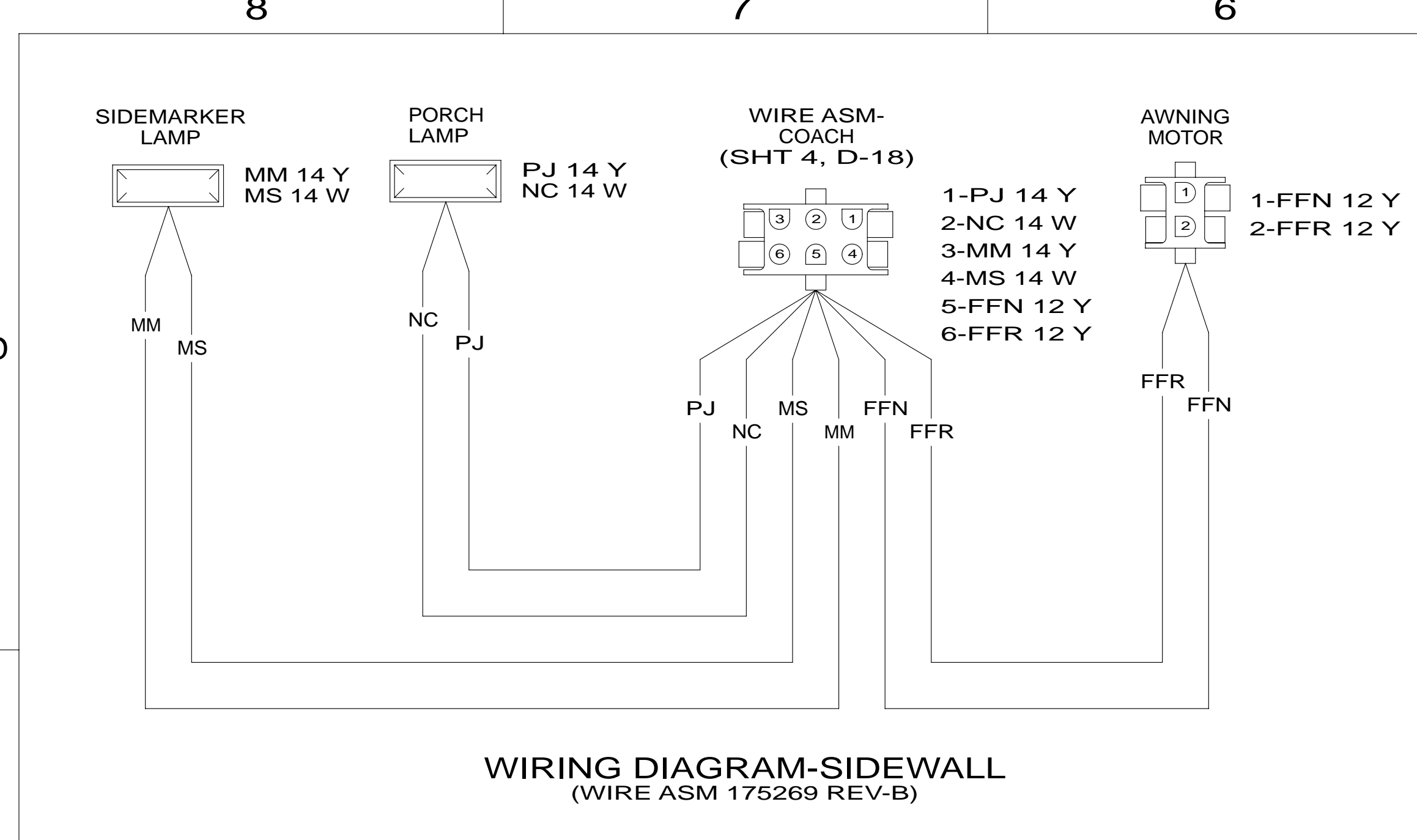

1. SPLICES ARE THEORETICAL AND MAY DIFFER IN THE HARNESS.

NOTES:

FIRST USED	<b>13 E35F</b>	
DO NOT SCALE DRAWING		
TITLE: <b>WIRING DIAGRAM-BODY,12V</b>		
SHEET 6	PART NO <b>183959</b>	REV
		12-Sep-2012

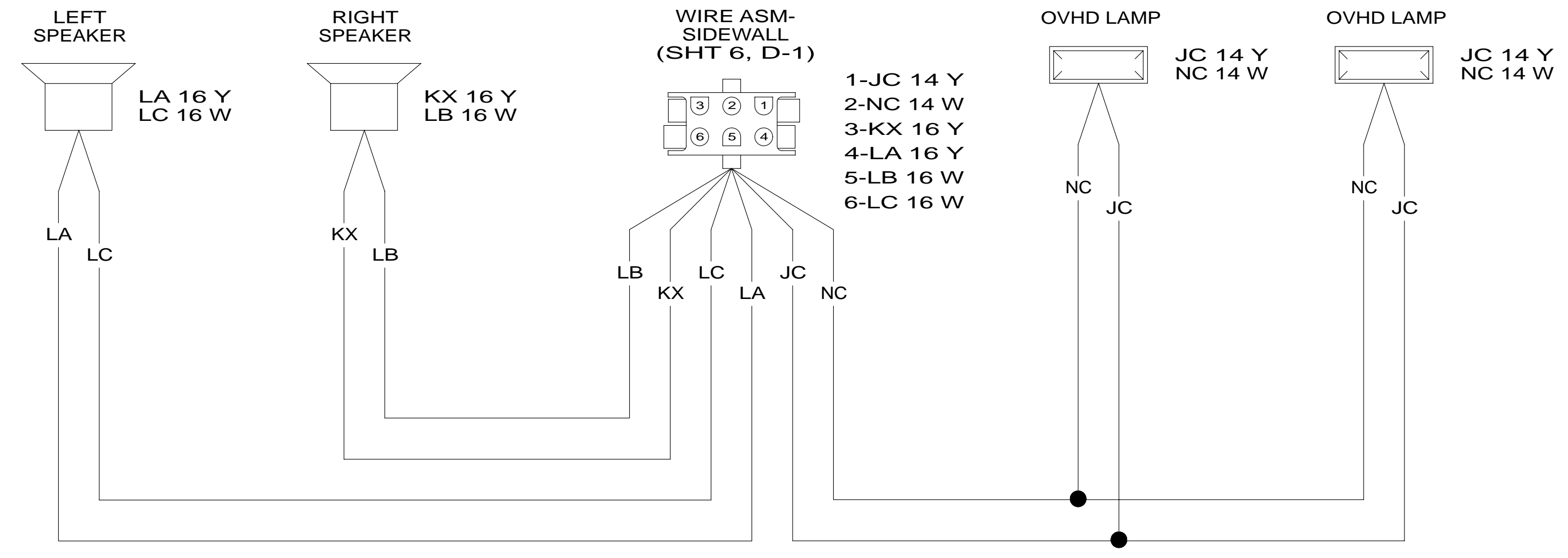

WIRING DIAGRAM-OVHD  
(WIRE ASM 175158 REV-A)

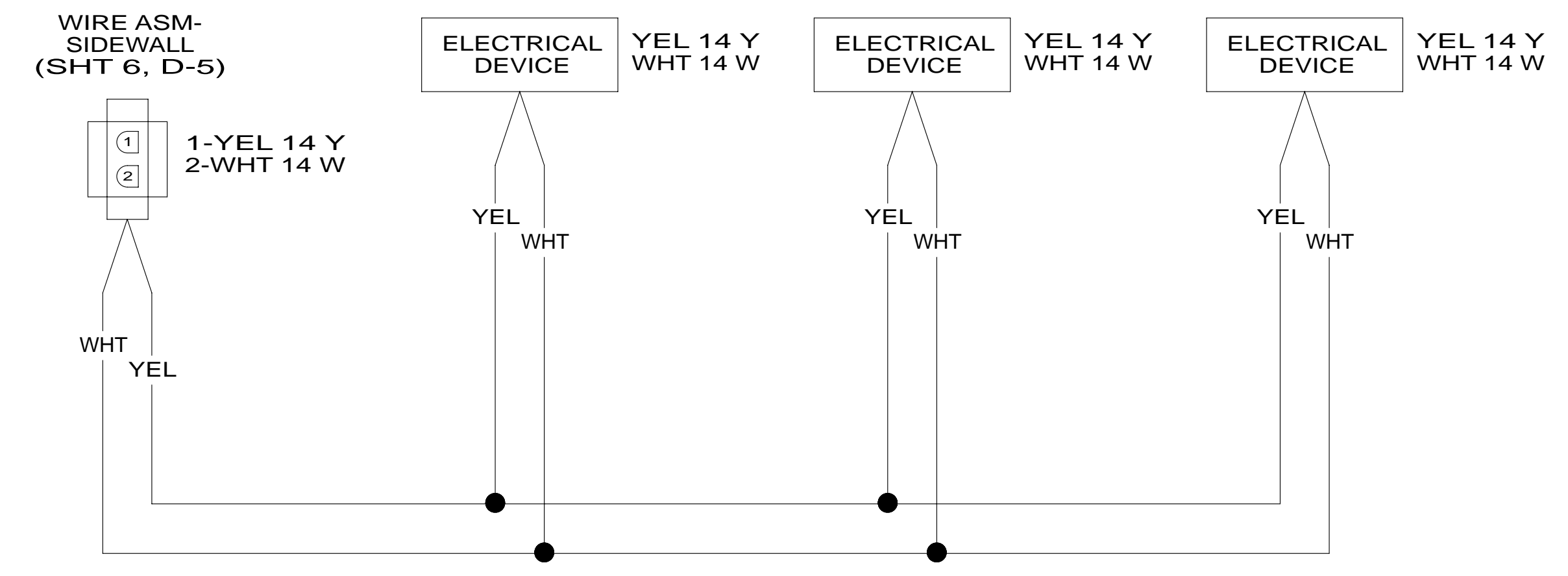

WIRING DIAGRAM-OVHD  
(WIRE ASM 139779 REV-M)

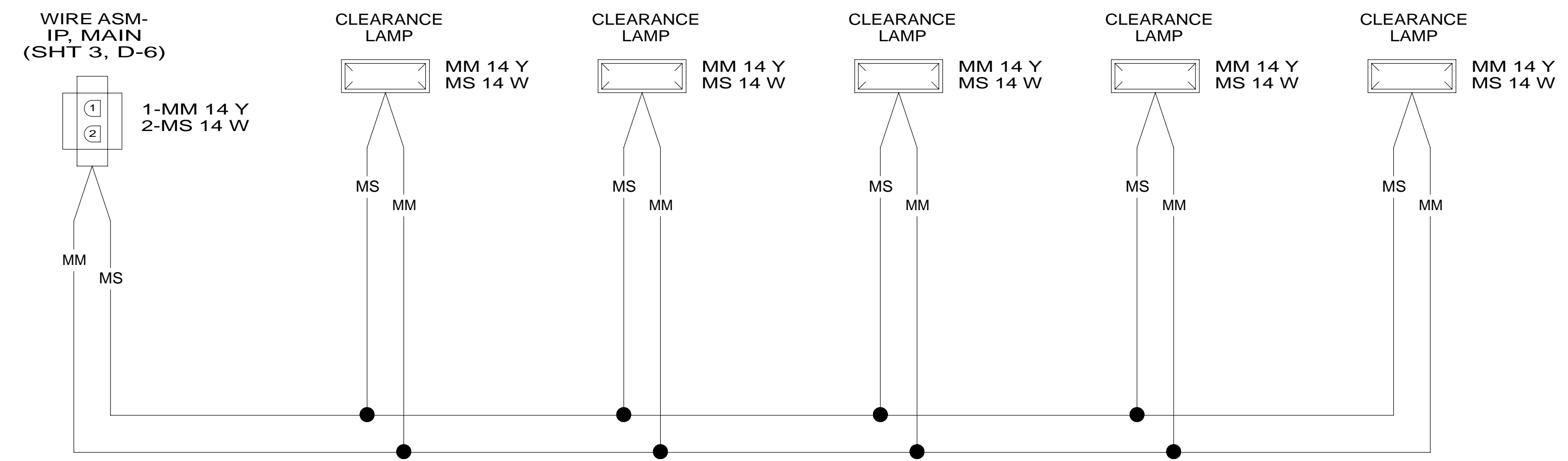

WIRING DIAGRAM-CLEARANCE LAMPS  
(WIRE ASM 129943 REV-D)

1. SPLICES ARE THEORETICAL AND MAY DIFFER IN THE HARNESS.

NOTES:

FIRST USED	<b>13 E35F</b>	
DO NOT SCALE DRAWING		
TITLE: <b>WIRING DIAGRAM-BODY,12V</b>		
SHEET 7	PART NO <b>183959</b>	REV
		1 12-Sep-2012